

Section 7A

Frame/Pegs



452

Chrome Left Side Covers for FL 74 & 80

Left side cover includes oil tank top cover, Knobs and mounting hardware.

- 452** 1965-69
- 454** 1978-82



2418

Chrome Right Side Cover for FL 74 & 80

Comes with mounting hardware.

- 457** Fits 1977
- 458** Fits 1978-84
- 2418** Fits 1982 Belt and chain drive

- Floorboards 33-37
- Foot Pegs and Mounts 38-44
- Forward Controls 27-33
- Frame Covers 1, 6, 8
- Frames.....2-8
- Highway Bars 16-18
- Kickstands 19-22
- Motor Mounts 23-26
- Lowering Kits (Sportster)14
- Shocks 13-15
- Swing Arm10-12
- Tool Box 9

V-Twin Frame



99852



99854

V-Twin Replica Swing Arm Frame FLH

Authentic reproduction FLH style frame for 1958-84. Accepts Pan or Shovel engines, 4 speed transmissions, seat posts and round or square swing arms. Includes forged parts in neck (as original), motor mounts, front trans mount, top seat post yoke, strut and swing arm pivot mount and floorboard mounts, as required. All stamped components are pressed and formed to stock specifications.

1958-64 Style

Accepts a 6 volt battery, early wrap around tank and includes footboard tabs. Neck will accept lock assembly. Features a low seat area.

99852

1965-68 Style

Accepts a 12 volt electric start system as stock. Neck will accept lock assembly

99853

1969-84 Style

Accepts a 12 volt electric system. Neck includes 17 digit serial number boss and tab for stem padlock.

99854

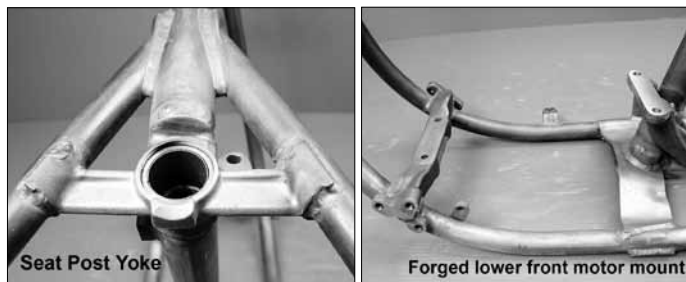

Seat Post Yoke

Forged lower front motor mount



99853
Neck Detail



99853

V-Twin Knucklehead Frame

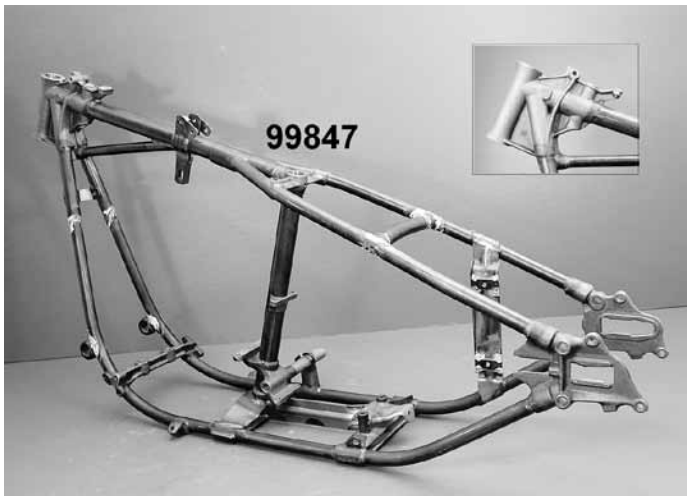

V-Twin Replica Knucklehead Frame

Authentic reproduction of the factory style frame. Features forged parts, as original, in neck, front and rear motor mounts, side car loops, top seat yoke, floorboard tabs and rear axle plates. Exact blanked and formed stampings are used in appropriate areas. Rear fender cross bar is supported by exact duplicated "saddles" brazed at each end. Includes installed seat post and mechanical brake cross shaft bushings, tool box mount and grease fittings. The 28° or 29° neck angle will accept inline spring forks. The 30° neck angle on #99868 will accept offset spring forks. The frame will accommodate Knucklehead or Flathead engines and a 3 or 4 speed transmission only. Knucklehead frames require the separate purchase of clamp-on coil bracket kit PCP# 19684.

PCP	Year	Rake	Tool Box Mount	5th Mount	Tank Brace	Brake Tab
99847	1936	28°	Rectangle	No	7/8"	Open
99848	1937	28°	Rectangle	Yes	7/8"	Open
99849	1938-40 EL	28°	Round	Yes	1"	Closed
99855*	1941-E46	29°	2-Bolt	Yes	1"	Closed
99868*	L1946-47	30°	2-Bolt	Yes	1"	Closed

*Includes seat post, transmission plate and axle assembly



Rear Fender Mounting Strap
1936-57
19329



V-Twin Wishbone Frame



99857



99858

V-Twin Replica 1949-52 Wishbone Frame Kit

Authentic reproductions of BT rigid 1949-52 frames with a 30° rake. Includes assembled seat post, axle and transmission plate. Forged parts, as original, in neck, front and rear motor mounts, side car loops, top seat post yoke, floorboard tabs and rear axle plates. Exact blanked and formed stampings are utilized in their respective places with the correct tool box mount. Neck will accept key lock. Mechanical brake cross shaft bushings, tool box mount and grease fittings are installed. Frame has cable mount tab under gas tank on the cross bar. Frame will accept Panhead or Shovelhead motor and a 4 speed transmission. Will also accept Knucklehead or Flathead engine with the use of a front engine mount spacer. Seat post bushing and mechanical brake cross tube bushing may require reaming prior to assembly. Supplied with an MSO, does not have serial numbers. As some bushings may require further reaming for proper fit, frames are not returnable and all sales are final.

PCP	Year
99857	1949-52

V-Twin Replica 1954 Wishbone Frame Kit

Authentic reproductions of BT rigid 1954 frames. Includes assembled seat post, axle and transmission plate. Forged parts, as original, in neck, front and rear motor mounts, side car loops, top seat post yoke, floorboard tabs and rear axle plates. Neck will accept key lock. Mechanical brake cross shaft bushings, tool box mount and grease fittings are installed. Frame has cable mount tab under gas tank on the cross bar. Frame will accept Panhead or Shovelhead motor and a 4 speed transmission. Will also accept Knucklehead or Flathead engine with the use of a 3/8" engine mount spacer. Seat post bushing and mechanical brake cross tube bushing may require reaming prior to assembly. Supplied with an MSO, does not have serial numbers. As some bushings may require further reaming for proper fit, frames are not returnable and all sales are final.

PCP	Year
99858	1954



19696



19697



19695

BT Top Motor Mounts

Mounts are 2 halves with seat tee and rear tank mounts incorporated into the top mount. Weld-in place for accurate restoration.

PCP	Description
19695	1948-52 Pan
19696	1953-69 Pan-Shovel
19697	1970-84 Shovel



Rear Section

Demonstrated forged rear axle plates and replica tool box mount for an authentic look.



Seat Area

Utilizes cast yoke to accept the included stock seat post bushing. Rear down tube has cast front oil tank mount and coil mount blocks installed. Lower tube bushing is welded to secure lower seat post lock nut.



Frame Related

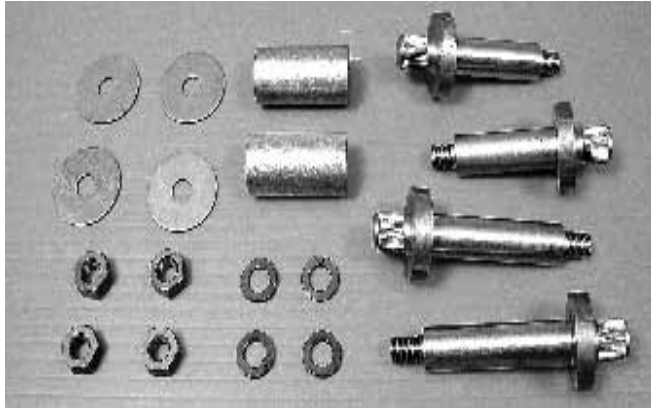

Sidecar Body Support Rods Stud Repair Kit

Complete kit contains studs, bushings, washers and nuts to re-build your support rods back to factory specs. Used on 1941-84 models.

72433



Colony Seat Post Rod, Nut and Spacer Kit

Reproduction of OEM 15-7/8" seat post rod. Includes nuts and spacers. For use on all 1936-80 BT except FX.

72612

Toolbox Bracket Details

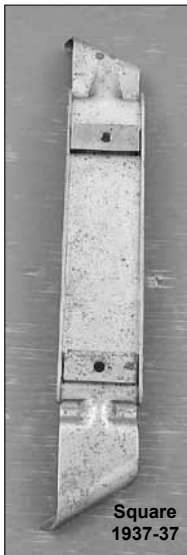

Square
1937-37

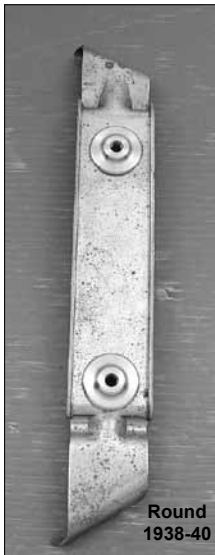

Round
1938-40

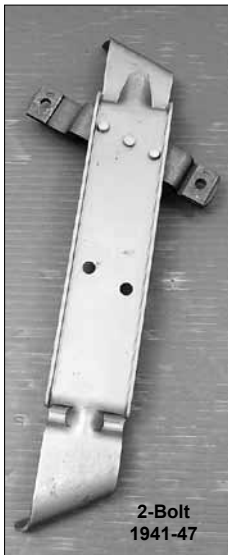

2-Bolt
1941-47

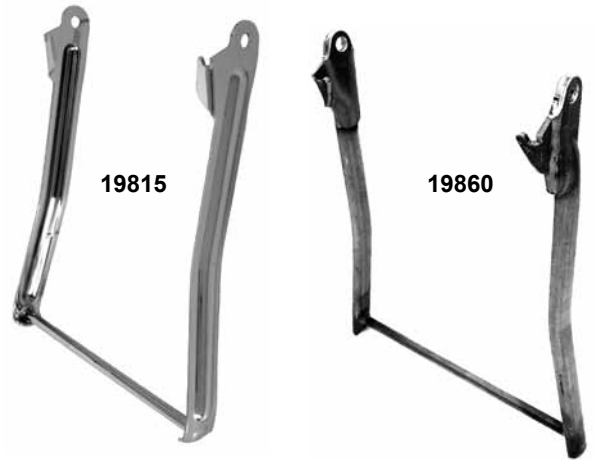

Rear Frame Stands

For rigid BT. Order stand catch and mounting hardware separately. PCP# 19860 is tubular.

Black	Chrome	Years	Model	OEM
19858	19815	38-57	74 & 80	49500-36
19860	19878	36-37 41-57	EL, UL FL	



Stand Catch 1936-57

Fits rigid 74 & 80 models. Replaces 49580-36.

Black	Chrome	Parkerized
3815	19272	27015

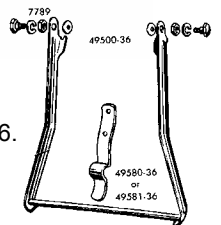

19022

Rear Stand Mounting Hardware

Parkerized hardware kits are an accurate reproduction of original Harley fasteners used to mount the rear stand.

- 19015** OHV 1936
- 19022** BT 1938-57
- 9616** As above, chrome

Frame

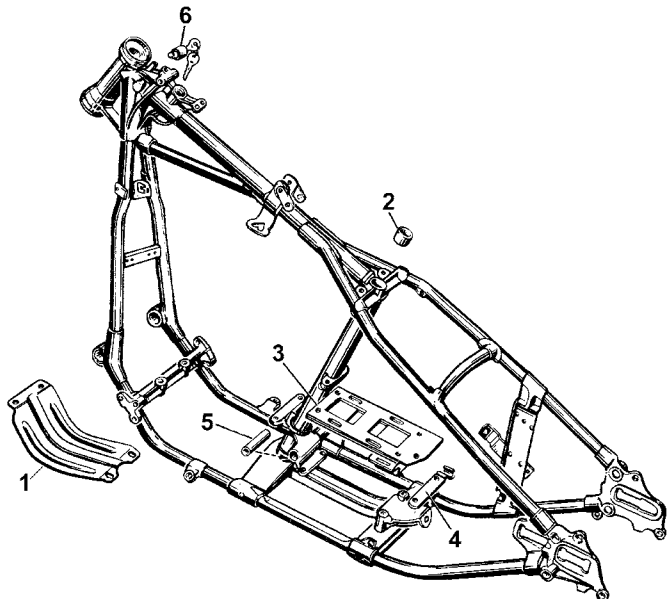

Big Twin Rigid Frame Components 1936-57

#	PCP	OEM	Description
1	3847 5477	24490-36	Chrome crankcase guard S.S. as above
2	18616	47583-36	Seat post bushing (each)
3	27249 27248	47698-36A	Trans base plate, (parkerized) Chrome, as above
4	231	47720-36	Support, trans adjusting screw 36-64
5	18585	47755-31	Brake crossover shaft bushing (pr)
6	27038	48150-30	Steering head lock 1930-68



SANTEE
CUSTOM CHROME MANUFACTURING

4 Speed Fat Bob Swingarm Frames

These 4 speed swingarm frames accept any BT engine, including Stokers. They have wider rear frame sections that accommodate either chain or factory rear belt final drives. Frames feature 33 degree neck angle (3 degrees over stock) combined with a 2" front leg stretch and include OEM style oil tank mounts which can easily be modified to accept other electric or kickstart oil tanks. OEM or aftermarket shocks, struts, and swingarms may be used with this frame. Each frame includes an MSO for registration.

99891 Frame with mounts for flatside Fat Bob tanks



45932 BT Stainless frame cover 1936-57

Big Twin Centre Stand 1958-64

Natural finish aluminum stand includes bushings and bolts.

27302 (49400-59A)

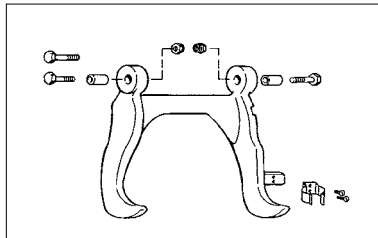

Mini Shock for Seat Post

Will replace BT seat post in 1936-80 frames. Includes adapter clevis to connect to "T".

21774

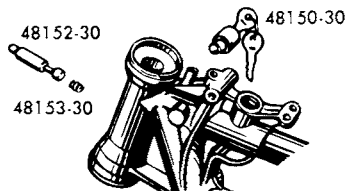

Steering Head Lock Assembly 1930-68
Includes cylinder lock, 2 keys, pin, frame plug and plunger.
27038

Weld-on Frame Tab

Weld-on right hand side frame mounting tab for all late model Harley 4-speed Big Twin frames without the mounting tab as original equipment. Ideal for mounting forward controls, relocating master cylinders to forward positions or installing highway pegs.
16526



BT Weld-on Rear Peg Mounts 1983-86

27317 3/8" Threads



Machined Side Car Loops

19395 1936-57



Colony Seat Post Bushings

Set of 2 precision machined bronze seat bushings for Big Twins 1958-84. Replaces 47094-58
72084

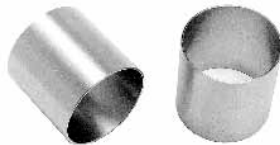

Colony Seat Post Bushing Installation Tool

Heat treated tool to install top and bottom seat post bushing on Big Twin 1958-84 models.
72085



Colony Seat Post Bushing Installation Tool

Heat treated with a black oxide finish. Use tool to install seat post bushing.
72086 BT 1936-57

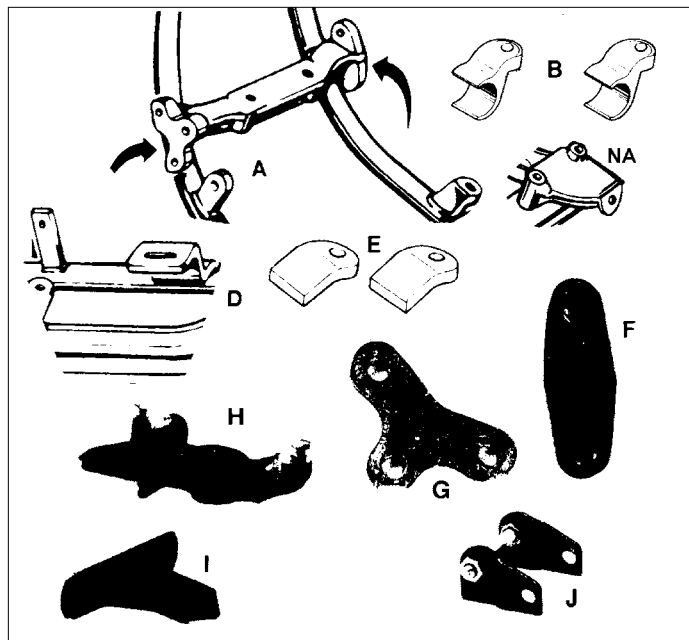

Big Twin Frame

Repair Parts to be welded on for exact restoration or repair.

PCP	Item	#	Note
16226	Floorboard tabs	B	Forged 1 1/8"
16325	Floorboard tabs	B	Forged 1" 1936-84
4556	5th Trans mount	D	
3778	Floorboard tabs	E	Stamped
4550	Right frame boss	F	2 Hole
4551	Left frame boss	G	3 Hole
1215	Bobbed tank mounts	H	Kit 3 piece
4552	Lower tank mount	I	Lower Y only
4557	Rear tank mount clips	J	Pair



Chrome Rigid Vibrator Bar

Fits between side car loops on BT 1936-57 stock rigid frame.
19118

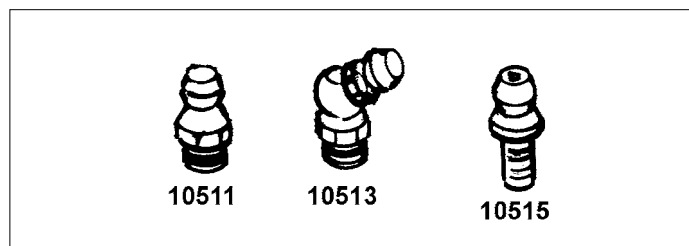

Grease Fittings 5/16 x 32 Thread

PCP	Description
5361	Nickel 1909-38 (6 pack)
10511	Zinc 1938-on (10 pack)
10513	Zinc, angle 1938-on (5 pack)
10515	Zinc 1979-84 for 4 speed rotary shifter (10 pack)

Frame Related



Chrome Side Covers for FXR 1982-94

Chromed steel side covers replace the standard plastic covers. Fit all FXR-FXRS models from 1982-94. Replaces (66351-82 (left), 66356-82 (right)).
3243 Complete set

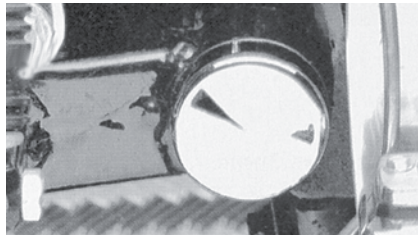

XL Swing Arm Pivot Bolt End Cap

Chrome diecast cover screws on over the swing arm pivot bolt on XL 1982-on models.
44105

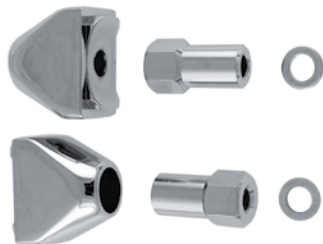

Chrome Pyramid Axle Adjuster

PCP Application
5586 XL 1979-96, FL and FX 1973-85 (pr)

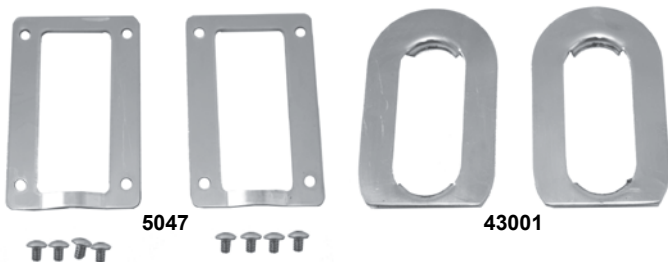

Axle Plates

Made of polished stainless steel to protect axle area. Pairs.
PCP Application
43001 1982-on FXR-FXRS
5047* 1936-72 Rigid BT and Swing Arm
 * Requires drilling and tapping at axle area (drill and tap not included), but includes screws.

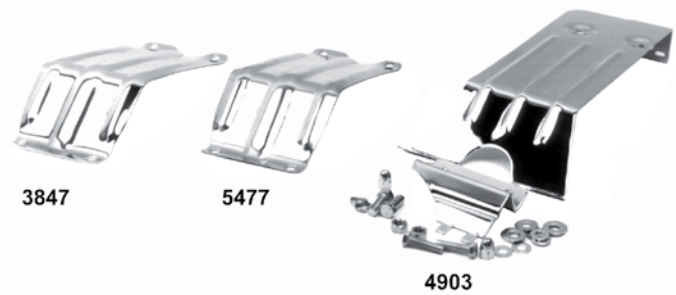

Engine Skid Plate

These skid plates incorporate ribs to add strength. Fits Big Twin 4 speeds 1936-84 (replaces OEM: 24490-36)
3847 Chrome engine crash plate
27283 As above, black finish
5477 Polished stainless steel skid plate

Chrome Engine Skid Plate for FXR 1982-88

This chrome plated skid engine plate is designed to protect engine cases from road hazards.
4903

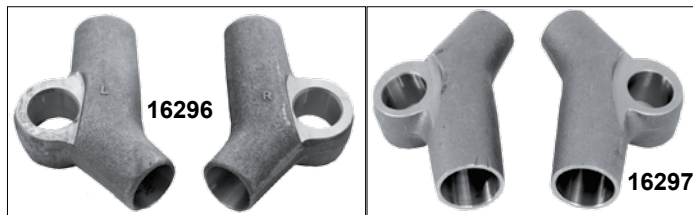
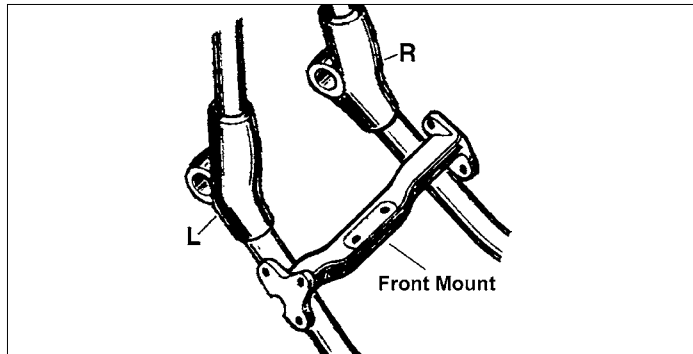

Front Side Car Frame Loops

Fits rigid frames with 1" diameter tubing and must be welded on. One piece, forged front motor mount has 3 holes on left side and 2 holes on right brake side.

PCP Description
16296 Straight leg side car loops (pr)
16297 Wishbone side car loops (pr)

Big Twin Motor Mount Shims

Fit on front and rear 1936-99.
PCP Thickness
13514 .036 (5 pack)
13515 .048 (5 pack)

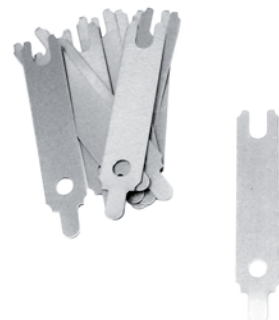

Tool Boxes



85203



2316



85201



85205



85202



2818

Big Twin Tool Boxes

Reproduction OEM type tool boxes complete with original style keys and locks. This is the ultimate addition to any vintage restoration or newly built custom motorcycle. Quality chrome plated, or black for OEM look as noted.

PCP	Description
2818	1936-39 Rectangular, chrome UL, Knuckle (3452-36)
85203	1936-39 Rectangular, black UL, Knuckle (3452-35A)
2316	1940-57 Chrome teardrop shape, R/S (64205-40C)
85201	1940-57 Chrome teardrop shape, L/S (64207-89A)
85202	Right side, black teardrop shape (64205-40A)
85205	1958-64 Oval, chrome teardrop shape (64205-40B)
2683	Replacement key (pair)

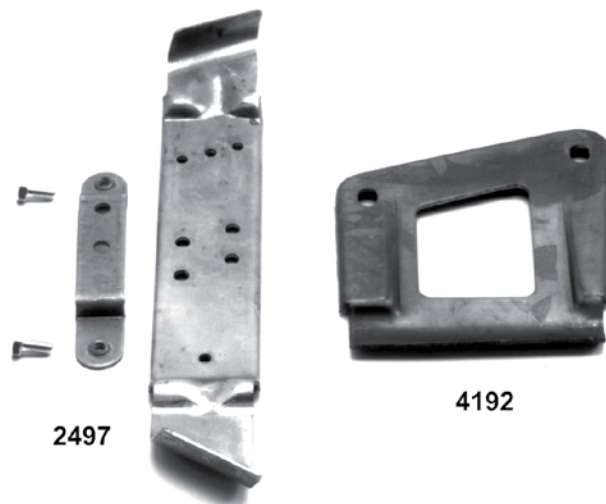

2497

4192



Tool Box Mounting Kit

Includes hardware necessary to mount the tool box.

PCP	Application
5204	All 1935-54 cad
9669	As above parkerized
72002	BT 1955-57 cad
72003	BT 1958-E62 cad
72004	BT L1962-64 cad
72005	K, KH, XL, XLH 1952-66 cad

Tool Box Brackets

Original style weld-on mounting brackets to mount our reproduction tool boxes on vintage Harleys. This bracket will work on stock as well as most custom rigid frames.

2497	1937-52 bracket mounts either the square (#2818) or kidney (#2316) tool box
4192	1954-57 bracket mounts the teardrop shape (#2316) tool box only
19599	1948-53 2 pc mount (replica)
19600	1948-53 Cross bracket (replica)
19601	1941-47 Cross bracket



Spark Plug Box

Clamps onto the rear frame tube just behind the oil tank and will house two spare spark plugs. This part will fit all Big Twin swingarm frames.

2315 91775-51T

Swing Arm



XLH-XLCH Swing Arm Pivot Kit

Complete kit includes all parts pictured for Sportster models 1952-80.

- 5266** 1952-73 Kit
5267 1974-80 Kit

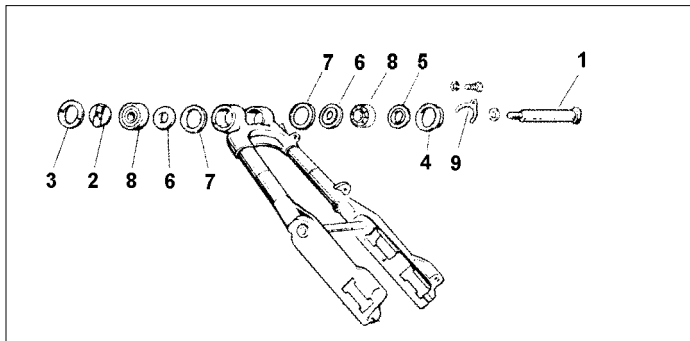

Swing Arm

	PCP	OEM	Year	Item
1	3693	47511-52	1954-80	Pin, chrome
2	12583	47512-52	1954-E74	Nut
2	12584	47512-74	L1974-79	Nut
3	12616	47514-52	1952-73	Locknut
3	12617	47514-74	1974-81	Locknut
4	12585	47515-52	1954-E74	Locknut
4	12586	47515-74	1974-81	Bearing retainer
5	11507	47517-52	1952-74	Spacer
5	11508	47517-74	1974-81	Spacer
6	11509	47518-52	1952-80	Spacer (pair)
7	3691	47519-52	1952-80	Dust shield (each)
8	15512	47521-52	1952-73	Bearings-2 Sets
8	15513	47521-74	1974-80	Bearings-2 Sets
9	13736	47525-52	1954-80	Lock (5 pk)

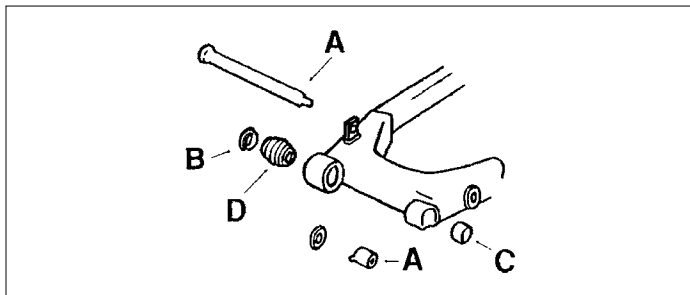

1981-85 Pivot Bolt Kit

Replaces 41568-81A which includes pin, screw, and spacer for Sportster 1981-85.

PCP	Item
21001	(A) Bolt and nut kit (41658-81A)
21002	(B) Dust cover (41579-81) (each)
21003	(C) Bushing L/S 1981-96 (47083-81) (each)
15561	(D) Bearing R/S 1981-97 (47082-81) (each)
43242	Pivot bolt kit 1981-97



74 & 80 Swing Arm Pivot Kit

Includes all parts pictured for a complete rebuild on all Big Twins 1958-84

PCP	Year	Description
2963	1958-72	Kit as pictured
2964	1973-85	Kit as pictured
10511	1938-on	Grease fitting (9851) (10 pack)
3312	1958-84	Spacers (47517-58) (pair)
13735	1958-85	Lock tabs (47513-58) (10 pack)
43200	1958-84	Pivot bolt, black (47510-58)
1300	1958-84	Pivot bolt, chrome (47510-58C)
15504	1958-84	Cup and cone (9052)
79409	1958-83	Seals (47519-58) (5 pack)
14068	1973-82	Seals (47519-72) (10 pack)



Swing Arm Bearing Assembly Kit, Sportster

Kit all parts necessary for Sportster 1952-80, chrome bolt.

- 27180** 1952-73
27181 1974-80

Swing Arm



FX-FL Swing Arms 1973-85

Available for Chain & Belt Drives. Bearings are not included. PCP #99201 has shock mounts welded $\frac{3}{4}$ " back for $1\frac{1}{4}$ " lowering. PCP # 99205 and 99206 come unassembled with shock and chain guard mounts loose to be welded on in the desired location.

PCP Application

6145	1972-84 Chain 4-speed BT and Paughco swingarm frames when using disc brakes, chrome $15\frac{3}{4}$ " c/c (47500-73)
99200	Chain, black (47500-73)
99204	4 speed belt drive frames and Paughco swingarm frames with Softail 5-speed transmissions, chrome (inside 9-3/4") $15\frac{3}{4}$ " c/c (47446-79)
99201	$1\frac{1}{4}$ " Lower chain, chrome
99202	$1\frac{1}{4}$ " Lower chain, raw
99211	Adjustable chain, raw



Swing Arm Pivot Bolts

PCP	OEM	Application	Finish
43200	47510-58	1958-84 BT	Black
1300	47510-58	1958-84 BT	Chrome
3693	47511-52	1954-80 XL	Chrome
21001	41658-81A	1980-81 FLT-FXR	Zinc
43204	47515-82A	1982-88 FLT-FXR	Zinc

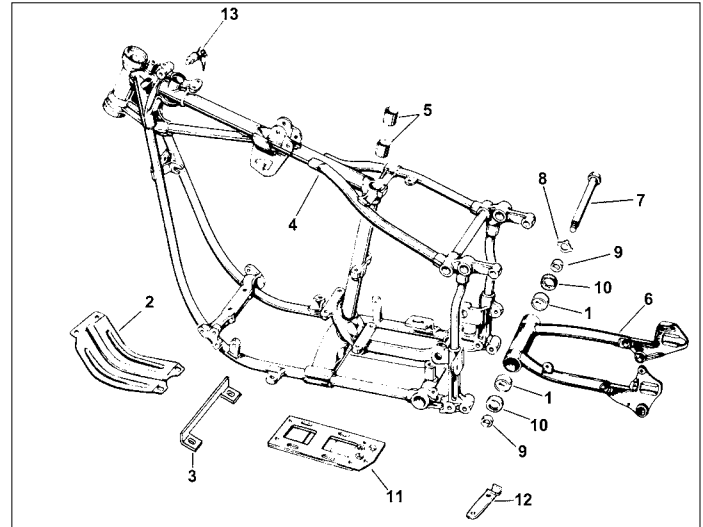

Big Twin Frame Components 1958-72

#	PCP	OEM	Description
1	15504	9052	Roller bearing 1958-84 (each)
2	3847	24490-36T	Crankcase guard, chrome 1936-84
	5477		As above, SS
3	13744	34747-65	Lock strip, trans mount bolts 1965-*
4	99852	47003-65	Replica frame 1958-64
	99853	47004-58B	Replica frame 1965-68
5	18584	47094-58	Bushing, seat post (each)
	72084	47094-58	As above, Colony (pair)
6	99209	47500-58B	Rear fork 1958-72
7	1300	47510-58	Pivot bolt, rear fork, chrome
	43200		As above, black
8	13735	47513-58	Lockwasher, pivot bolt (10 pk)
9	3312	47517-58	Spacer, pivot bearing, zinc (pair)
	43015		As above, chrome (each)
10	14067	47519-58	Seal, pivot bearing (.500) (10 pk)
	79409		As above, James (5 pk)
	14068	47519-72	Seal, pivot bearing (.410) 73-* (10)
	79410		As above, James (5 pk)
	14069	47519-83	Seal, pivot bearing (.250) 83-* (10)
	79412		As above, James (5 pk)
11	27261	47698-58A	Chrome trans mounting plate 58-84
	27262		As above, black
	27125	47698-65	Black trans mount plate 1965-84
	27261		Chrome plate 1958-84
12	231	47720-36	Support trans adj. screw 1936-64
13	27038	48150-30	Steering head lock 1930-68



Swing Arm Pivot Kit

Rebuild kit for all 4 speed Big Twins. Includes parts pictured. Features chrome bolt head

2965	1958-72 FL, FLH
2966	1973-85 FL, FLH, FX, FXE, FXS, FXWG
43203	1958-85 Special pin only (1" longer)

Swing Arm



FLT/FXR Swingarm Mounting Kits

Kit includes 2 bushing assemblies, 2 spacers, 2 plastic retainers rings, 2 rubber isolators and pivot shaft with locknut. Includes all parts required to mount transmission and swingarm to pivot block. Will work with stock or aftermarket rubber mount swing arm frames for FLT- FXR models.

PCP	Year
43202	1980-81
43206	1982-02

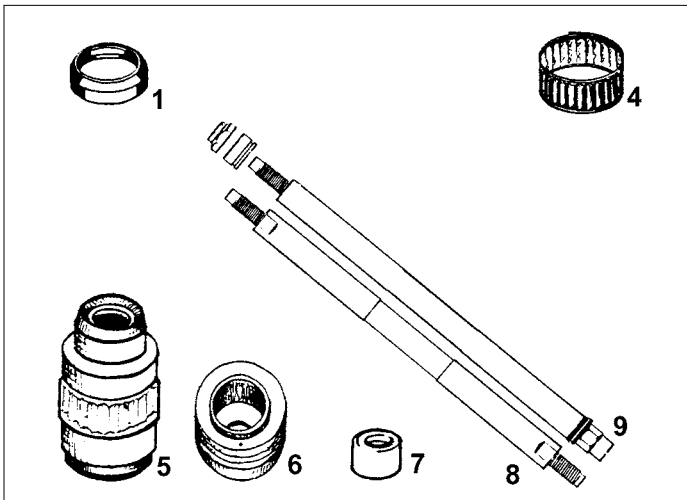

FLT/FXR Swingarm Rebuild Parts

#	PCP	OEM	Description
1	11101	47510-80	Plastic retaining ring 1980-02 (pr)
4	11300	47538-79	Bushing tolerance ring 79-02 (pr)
5	59970	47556-81	Bushing assembly 1981-02 (pr)
6	23019	47564-82	Rubber mount 1982-86 (pair)
8	43201	47515-80A	Shaft 1980-81
	43204	47515-82A	Shaft 1982-88, zinc



Colony Chrome Swing Arm End Plates

Chrome plated end plates are replicas of OEM 41112-79. Fits FXR 1981-94 and FLT 1979-on.

72090



FXR Swingarm End Cap Covers

Chrome covers for the swingarm pivot end caps on the 1982-on FXR. This is an easy way to dress up the sides of the bike.

44320 1982-89 (47850-88T)

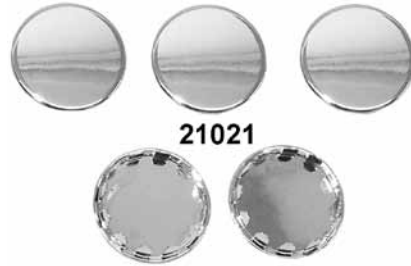

21021

FXR Swing Arm Chrome End Cap Plugs

Fits 1981-93 models. Replaces 67865-89. 5 Pack.

21021

Shocks



13" Shock Set

13" Shocks with 2" diameter chrome springs. Replaces 54568-79B to fit L1979-81 XL.

83563



Rear FL Chrome Shock Springs

Use to convert FL to FX style exposed chrome springs or to replace springs on FX models. Springs are stock tension.

PCP Fits

4611 11.5 Late chrome 1973-84 FX-FL (54555-73) (pair)

4612 13.5 Early chrome 1967-72 FL (54570-67) (pair)



Sportster Shock Stud Conversion

Stud kit updates 1954-74 XL Shock mounts to late model bushing diameters (1/2"). Kit includes four studs, four nuts and eight washers!

4610



Replacement Shock Sets

Each shock complete with springs, cams, pistons, and eye bolts, completely assembled. Available with chrome external springs or full chrome covers as FLH type.

FL-FLH-FX-FXE (Except FXR-FLT)

PCP	OEM	Type	Year	Length
2190	54509-73	Chr. springs	1973-85	12"
83500	—	Chr. springs and piston body	1973-85	12"
2191	54500-73	Full covered	1973-85	12"
83501*	1" shorter	Chr. springs	1973-85	11"
83502*	1" shorter	Full covered	1973-85	11"

*Feature Chr. body & springs, lowers bike.

FL-FLH/E.FX 1958-72

2251	54509-71A	Chr. springs	1958-72	13.5"
2189	54500-67T	Full covered	1958-72	13.5"

Sportster

83511	54500-56A	Full covered	1952-74	14"
83514	54504-73	Chr. springs	1955-74	14"
83515	54490-78	Chr. springs	1975-78	14.5"

Adjustment: With the shock tool firmly set in the lower cover's holes, slowly turn the wrench and the lower cover clockwise, (as viewed from above). This action will turn a set of locking cams within the shock, increasing the tension on the shock spring.



Dura-Series Shock Sets

Shocks are nitrogen charged with multi-stage dampening and adjustable spring load. All shocks feature black body, chrome springs and caps and are measured eyelet to eyelet.

11"	11.5"	Application
83520	83521	1980-02 FLT-FLHT

Shock Covers/Studs



Upper Shock Stud Kits (Zinc)

Sold as pictured.

PCP Description

- 4621** FL 1958-66 (54515-58A)
- 4622** FL, FX 1967-72 (54515-67)
- 4623** FL, FX 4-speed models 1973-86 (54515-73)
- 4624** XL 1956-74 (54515-56B)



Lower Shock Stud Kits (Zinc)

Sold as pictured.

PCP Description

- 4625** FL 1958-66 (54517-58)
- 4626** FL, FX 1967-72 (54517-67)
- 4627*** FL, FX 4-speed models 1973-86 (3958)
- 4628** XL 1956-74 (54516-72)
- 4629*** XLX, XLS 1982-on (4081)
- 4630*** FXR 1982-on (1614)

*Note each kit has 2 chrome nugget nuts



Shock Stud Conversion

Allows the use of shocks with 1/2" holes with steel inserts. Simply press out stock bushing and sleeve and replace with the 2 piece style. This fits the 5/8 diameter studs on many models. Use a 5/8 cup washer for final assembly. Set of 8 rubbers.

- 16234** Rubber bushing (8 pcs)
- 4617** 5/8" Cup washer (54544-65) (10 pack)



Chrome Shock Covers

Dome style shock top covers fit all models of swingarm 4-speed Harleys with stock shocks; Sportster 1952-75; Big Twins 1958-84 without saddlebag guards. Sold in pairs.

- 2183** 54707-84T

Note: These covers are as stock replacement for XL, K's 1952-64 & FL's 1958-64. Other applications are custom. Some seats may cause interference.



Sportster Rear Shock Lowering Kits (Black)

These kits lower the rear shock area. Includes instructions, hardware and brackets.

- 27026** 1982-85 XL, lowers 1"



Shock Spring Covers

Chrome plated replacement spring covers for all 1967-on Big Twins. Early type replaces OEM 54702-67. Fits 13.5" type shock used on all 1958-72 Big Twins. Late type replaces OEM 54702-73. Fits 12" type shock used on all 1973-86 Big Twins 4 speeds (except FLT-FXR).

- | PCP | Fits | Length |
|-------------|---------------|---------|
| 4606 | 1967-72FL-FX | 9 1/2" |
| 4607 | 1973-84 FL-FX | 8" |
| 4608 | 1954-74 XL | 10 3/4" |

Shock Hardware



Shock Spanner Wrenches

PCP	Model
2837	1975-78 Sportster (Gabriel) (94820-75)
1319	1979-on Sportster, 1980-on FXR- FLT (94409-78, 94448-82)
1317	1978-85 FL-FLH, 1982-on FX-FXE (94408-78, 94444-82)
2836	1952-74 Sportster, 1958-81 FL-FX (scissor type) (94700-52B)

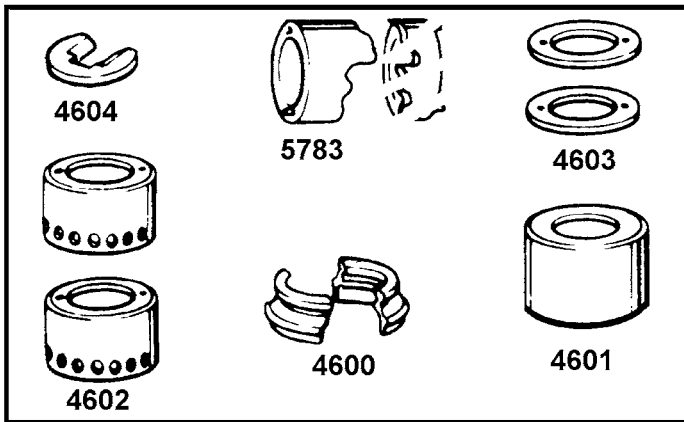

Replacement Hardware

Fits stock or aftermarket shocks 1967-on top clip type.

PCP	Item
4603	Washer (6910W) (10 pack)
4604	Cam lock (54538-73)
5783	Cam (pair of lower cams only) (54558-73)
4602	Cam sleeve (54559-73) (pair)
4600	Spring retainer (54635-67) (pair)
4601	Upper cover (54700-67) (pair)

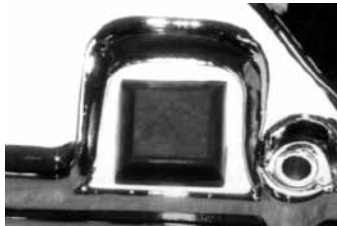

Kickstand Bumper Pad

Kickstand bumper pad complete with adhesive backing to protect primary cover from the return of the jiffy stand. Fits all Big Twin 4-speeds 1970-86. (OEM 50100-70).

23028 Sold in 5 packs



Shock Stud Covers for Harley

Chrome plated stud covers for Harley Big Twins and Sportsters. Sold in pairs.

PCP	Description
2508	FL\FX 1970-84, XL models 1965-74 (54704-65T)
2507	XL models 1975-78 (54704-75TA)
45058	XL 1982-90, FXR 1982-94 (57408-88TA)

Shock Stud Lock

Nuts 5/8-18

Replaces OEM 7993.

4614 Pair



Shock Stud Spacers

Replaces 5960W on 1965-85 FLH when crash bars are not used. Zinc plated.

11703 Pair

Shock Stud Cup Washer

Chrome plated replacement washers.

Sold in packs of 10 only.

PCP	Description
4617	5/8" cup washer (54544-65)
4618	3/8" cup washer (54543-65)
4619	1/2" cup washer (54545-65)
4620	1/2 x 1" flat washer (6718)

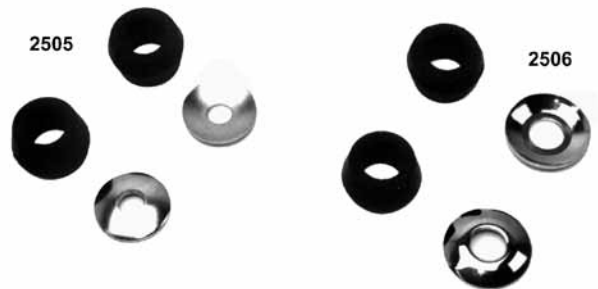

Set of Shock Stud Rubbers and Chrome Washers

2505	For stud with 3/8" x 24 TPI (set for 1 stud)
2506	For stud with 1/2" x 20 TPI (set for 1 stud)



Rubber Shock Bushing

A bag of 8 rubber bushings for the Harley shock mounting studs. OEM 85210-42A. Enough to service 2 shocks.

4605 8 pack

Highway Bars

For Front Highway Bars Listed on this page.

WARNING: These Engine/Frame Bar may provide limited leg and cosmetic vehicle protection under unique circumstances (fall over while stopped, very low speed slide). They are not made nor intended to provide protection from bodily injury in a collision with an automobile or any other object.

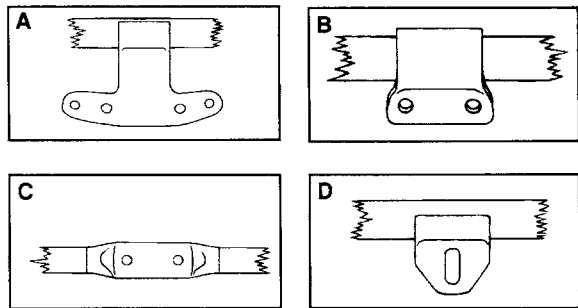
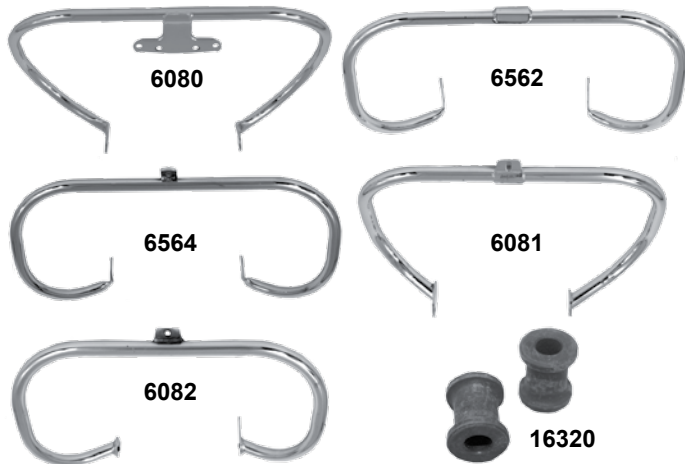

PCP	OEM	Year	Model
6080	49038-36	1936-47	BT 74-80 1955-57 straight leg 1" (A)
6562	49038-49	1948-E54	BT 74-80 1" Wish Bone (B)
84114	49038-49	1948-52	BT 1" Wish Bone w/flat mount (C)
84115	49038-49	1948-52	As above, black
84159	49038-48	1948-E54	1" Wish Bone frame
16320	49059-48	1948-53	Spacers (pr)
6564	49038-58B	1958-78	SA, BT, FL 1"
6081	49058-58B	1958-78	SA, BT, FLH 1-1/4" (D)
6082	49040-79	1979-84	FLH, SA 1-1/4"
84101	49016-72D	1972-up	T/L FX-FXE-FXWG 1-1/4"
84102	49017-82A	1982-94	FXR to '00, FXRT 1989-92
84105	49042-56A	1956-81	XLH
27117			Lower Mount w/clamps FX



84105 Front Sportster 1956-81 style (49042-56A)



Black Front Engine Bar

Fits 1936-38 UL, EL and 1955-57 FL.

84157



Chrome Billet Foot Peg Kit for Engine Bar

Foot peg and mount kit fits on 1-1/4" front engine bars with male pegs.

59222

Leggins

Splash and weather shields which attach to front engine bar by easy close snaps. Made from heavy naugahyde construction.

PCP Application
29405 FLH 1936-84



Highway Bars

WARNING: These Engine/Frame Bar may provide limited leg and cosmetic vehicle protection under unique circumstances (fall over while stopped, very low speed slide). They are not made nor intended to provide protection from bodily injury in a collision with an automobile or any other object.



Chrome Billet Engine Bar Foot Peg Mount

Fits on 1-1/4" engine bars to accept male pegs on front engine bars.

59204



Chrome Dual Fog Lamp Kit

Features flat oval diecast lamps with 55 watt halogen bulbs. Chrome alloy clamps fasten to all 1-1/4" engine guards.

66122 Set (68913-98B)



Safety Guard Mounting Kit

Parkerized U-bolts replace OEM 49064-36. Kit includes U-bolts, nuts and lockwashers to mount safety guard on 1937-47 61", 74" and 80" models.

72203

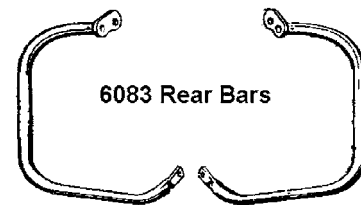
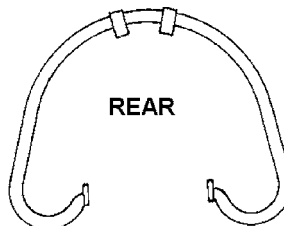
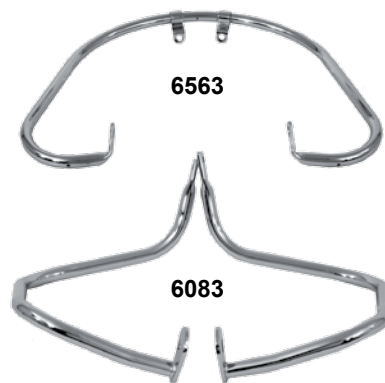

Rear Frame Bars

PCP	Application	Finish
6563	1936-57 BT 74	Chrome (49153-36)
84001	1936-57 BT 74	Black (49153-36)
84004	1965-66 FL-FLH	Chrome (49137-65)
84002	1958-64 FL-FLH	Chrome (49150-58A)
6083	1967-84 FL-FLH	Chrome (49137-67B)



Stock Shock Stud Spacers

Replace 5960W on FLH 1965-85 when rear frame bars are not used. Zinc plated, pair.

11703



BT Rear Frame Bar Mounting Kit

Fits BT 1936-57. **PCP** Description

9530	Chrome bolt kit
9531	Cadium bolt kit
9532	Parkerized bolt kit
24066	Black upper bolts (pair)
24067	Zinc lower bolt kit (6pcs)

Highway Bars

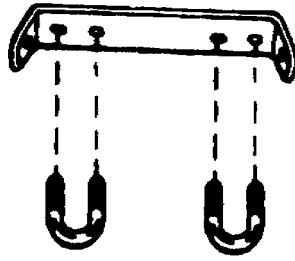

“U” Clamps

Forged design like OEM.

PCP	OEM	Application
19279	13051-36	74-80 Front engine bar (pr)
19341		As above, chrome
19280	31734-36	74-80 Spark coil (pr)
19282	38460-52	Mouse trap booster clamp, Police shifter clamp (ea)
19283	49064-36	Side car front clamp (pr)
19285	87701-79	Rear late side car (pr)



Front Safety Guard Mounting Kits

U-bolts (49064-36), nuts and lockwashers to mount safety guard on 1937-47 61", 74" and 80" BT models.

Chrome	Parkerized	Year	Application	OEM
72204	72203	37-47 55-57	61", 74", 80" BT Panheads	49064-36



BT Rear Frame Bar Mounting Kit

Fits BT 1936-57. Order PCP# 24068 upper bolt studs when you want to leave fender bolted in place after removing the bar.

PCP	Description
9530	Chrome bolt kit
9531	Cadium bolt kit
9532	Parkerized bolt kit (shown)
24066	Black upper bolts
24067	Zinc lower bolt kit (6pcs)



Colony Front Safety Guard Mounting Kit

Parkerized spacers (49059-48), bolts (4051), nuts and washers. For use on 1948-50 61" and 74" Twins.

72477



Colony Front Safety Guard Mounting Kit

OEM style cad fasteners used on 1958-69 FL.

72495



Colony Front Crash Bar Mounting Kit

Correct fasteners used to mount crash bar on 1951-54 BT.

72630 Chrome

72631 Cad

Side Stand

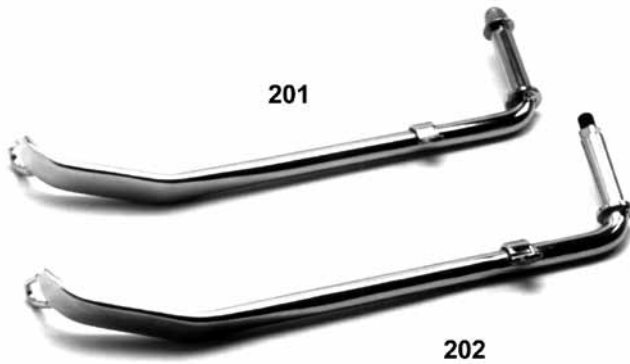

Original Style Kickstands

Fits 74" & 80" 4-speed models 1936-88 (OEM 50061-36).

- 201 Stock length
- 43220 For 2"-4" over forks
- 202 For 4"-6" over forks

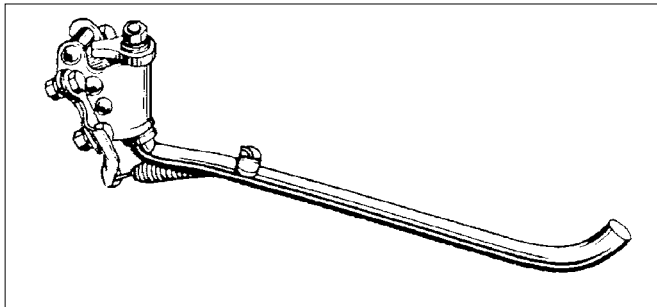

Stock Type Jiffy Stand Assembly

Fits Big Twin rigids 1936-57. Includes bracket, lock tab, spring, spring tab, leg and hardware.

- | PCP | Finish |
|-------|---------------------------------|
| 27164 | Black and parkerized (50003-36) |
| 43381 | Chrome |



FXWG Style Kickstand 1936-84

Replaces 50040-80.

- 1225 Chrome stock length
- 43221 1" O.S. for 2"-4" extended fork tubes



Custom Jiffy Stand Assembly

Features full forged construction with chrome smooth contour design, including recessed mount screws for 1936-86 BT, 4 speed models. Stock length.

59206



Chrome Smooth Kickstand Bracket

One piece forged design with recessed mount hardware for PCP# 59206 forged stand kit. Does not work with OEM style.

59205



Jiffy Stand and Foot Clutch Lever Bracket Mounting Kit

Nuts, bolts and washers are duplicates of OEM hardware used on Big Twins 1936-78.

- | PCP | Description |
|------|-------------|
| 9617 | Chrome |
| 9618 | Cad |
| 9619 | Parkerized |

Side Stand



699

FXR Jiffy Stand Unit

Chrome plated stock replacement kickstand, for all 1982-89 FXR's. (50069-82).

699



43224



43225



43226



43227



43228

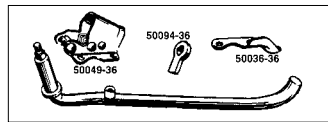

Round Style Stock Jiffy Stand Legs and Parts 1936-84

PCP	Item	Fitment	Finish
43224	Leg	BT 1936-57	Black (50061-36)
43225	Leg	BT 1936-57	Parkerized
43226	Leg	BT 1936-57	Cadmium
43227	Leg	BT 1936-57	Chrome
43228	Leg	BT 1936-57	Chrome
13233	Spring	1936-84	Black (50011-30)
13236	Spring	1936-84	Parkerized
27188	Spring clip	1936-84	Parkerized (50036-36)
27187	Bracket	1936-84	Parkerized (50049-36)
73513	Bracket	1936-57	Parkerized (50046-36)
27204	Lock tab	1936-84	Black (50094-36)



Replica Kickstand Mount Kit BT 1937-57

Includes bracket, spring, clip, locktab and mount hardware.

43382 Parkerized

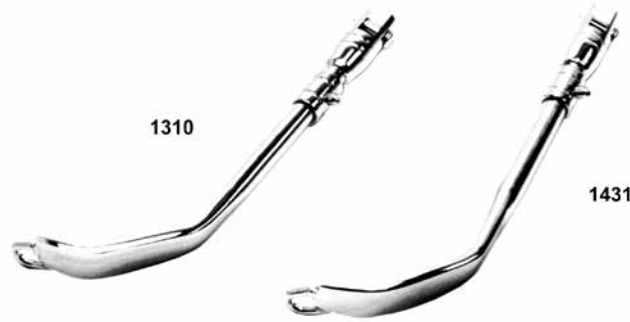

1310

1431

Custom Kickstands for Sportster 1957-E84

These custom all-chrome kickstands are made for Sportsters to E1984.

- 1310 For stock length forks 1952-E84 (50006-80)
- 43231 Stock chrome 1952-E84 (50062-52A) (round)
- 1431 +1" for 4"-6" overlength forks
- 24440 Replacement bolts (10 pk)
- 72079 Pin for #43231
- 13230 Spring 1952-E84 (50011-30)

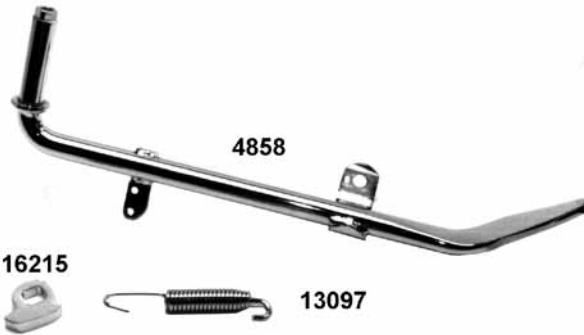

4858

16215

13097

Sportster Kickstand 1984-88

Fit 1984-on Sportster 883-1100 1200 in chrome.

- | PCP | Item |
|-------|-------------------|
| 16215 | Catch (50038-84) |
| 13097 | Spring (41836-84) |
| 4858 | Stand (50006-84A) |
| 43215 | 4"-6" Stand |

Side Stand

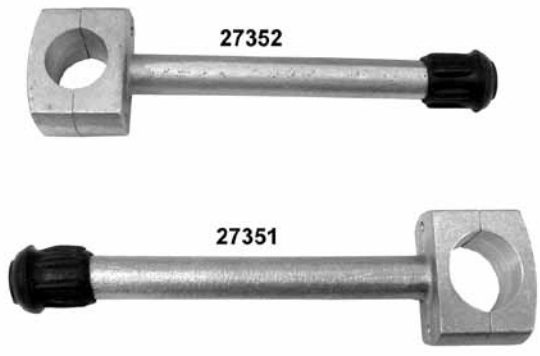

Frame Mount Kickstand Stop

For use on all open belt Big Twin by clamping to frame tube. Cut to desired length.

PCP	Size
27351	1-1/8" I.D.
27352	1" I.D.

Kickstand Bumper Pad

Use on all 1970-86 Big Twins with aluminum primary. Adhesive backed for quick installation.

PCP	Application
23028	1970-86 BT (50100-70) (5 pk)



Chrome Jiffy Stand

27244 FLT 1983-90 (50075-83A)



FLT Chrome Jiffy Stand Kit

Kits include jiffy stand leg, spring, bracket and bumper stop with mount hardware.

43235 1983-90

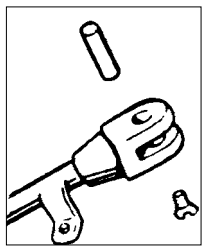

Pin, Jiffy Stand

Replaces OEM 65090-53. Fits all 1954-E84 XL's. Complete with set screw.

72079



Chrome Kickstand Tab Kit FLT 1980-on

Kit includes washer, spring, acorn nut and tab.

59137

Kickstand Hardware



Big Twin Chrome Kickstand Hardware

PCP	Description
4398	Mount bracket w/spring tab 1936-86 (50041-80)
204	Mount bracket 1936-86 (50049-36, 50014-74A)
205	Spring plate BT 1936-86 (50028-74T)
206	Leg stop 1936-86 BT, FLT 1980-03 (50094-36, 50015-74)
27307	Mount bracket FLT 1981-08 (50078-81)



Kickstand Springs

PCP	Description
13230	BT 36-85, XL 52-83, FXR 80-89 chrome (50011-30)
13233	As above black
13232	45 Solo 1930-52, zinc or black (50012-30)
13231	As above, chrome (50012-30)
13097	1984-88 Sportster, chrome (41836-84)



Big Twin Complete Kickstand Mounting Kit

Works on all Big Twins 1936-on. Includes kickstand mount spring leg stop and spring plate. Chrome plated.

4399



Acorn Kickstand Mounting Kit

Fits Big Twin 4 speed 1936-86

1803



BT Adjustable Kickstand Stop

The chrome steel kickstand stop eliminates the need for glue on rubber bumper pad while protecting the primary case. A nylon tipped set screw allows easy adjustment for proper kickstand position. Fits FL, FX 4 speed 1958-84 (not FXWG).

27141

Kickstand Lowering Wedge

Fits under BT mount bracket to change angle of bracket and assembly when using shock and fork lowering kits.

27043

Motor Mounts



3289

4490

Chrome Top Motor Mounts BT 1948-84

This top motor mount and coil bracket combination replaces the stock mount and allows you to use our new style Harley 6 or 12 volt coils.

3289 Mount with switch hole

4490 Without switch hole



74" BT Motor Mount with Linkert Bracket

Features welded on Linkert choke bracket. Stock on 1948-65 FLH and replaces 16853-48.

PCP **Finish**

4492 Chrome

40107 Cadmium



Stock Top Motor Mount

Complete one piece top motor mount with a chrome finish for FX models 1973-80 FX, FXE. Replaces OEM 69018-73TA.

1371



Chrome FL Stock Top Motor Mount 1967-84

Fits all 1948-83 Big Twins. Replaces OEM 16852-67A.

1372



Chrome Super Heavy Duty Two-Piece Top Motor Mount

For all 74s & 80s, stock or strokers. 1/4" thick. 1948-84.

3421

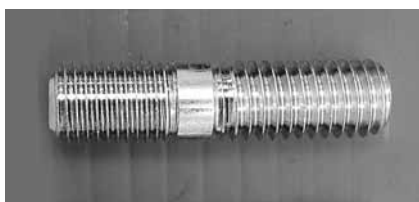

Motor Mount Bracket Stud

Fits BT 1949-84. Sold Each.

10817 16864-48



Stock Top Motor Mount

Complete one piece top motor mount with a chrome finish for FX models 1977-84, FXB, FXEF, FXS. Replaces OEM 69013-77TB.

1373



Knuckle Head Top Motor Mount Kit

Fits 1936-47, 61 & 74 model OHV.

19053 Black 1940-47 (16853-38)

19055 Chrome 1938-47

19330 Black 1936-37 (2806-36)

72648 Cadmium bolt kit (9 Pc)

72649 Parkerized bolt kit (9 Pc)



Motor Mounts



40021



40060



40022



30056

FLT-FXR Front Motor Mounts

Replaces front bottom engine mounts for rubber mounted engines. Fits 1979-08 FLT 5 speeds and 1982-94 FXR models. Replaces 16207-79B

PCP Description

- 40021** Black
- 40060** Sifton with anti-vibration polyurethane compound
- 40022** Chrome
- 30056** Velva-Ride, black finish with anti-vibration compound
- 21000** Front bracket FLT 1980-06,(47159-79A)



21000



4494

4495

4496



40019



40054

FL, FX Heavy Duty Maxi Motor Mounts

These chrome multi-piece top motor mounts are 1/4" thick, stronger than the conventional 1 piece mounts. Suitable for stock or stroker motors.

- 4494** Fits FL 1967-84, FX 1971-84 without remote mounted ignition switch and choke (16852-87T)
- 4495** Fits FX 1977-84 with choke tab only (69013-87T)
- 4496** Fits FX/FXE 73-80 w/choke and ignition switch tabs (69018-87T)



40025

FLT Chrome Top Motor Mount

2 Piece design to mount rubber engines in stock or custom solid mount frames.

- 40025** Shovel 1980-83 (47169-79, 29227-79)

Stabilizer Linkages

Features a steel body with a urethane dampening plunger which together acts as a mini-shock absorber.

PCP	Fitment	Finish	OEM
40019	FLT 79-08 upper/lower FXR 82-94 upper/lower FXD 91-94 upper	Chrome	16219-79B
40054	FLT 79-08	Chrome	



Top Mount Stud Kits

Includes studs, washers and nuts. Studs also sold separately.

Cad	Parkerized	Year
72369	72368	48-65
72370	-	66-84
10817	Studs only (each)	

Motor Mounts

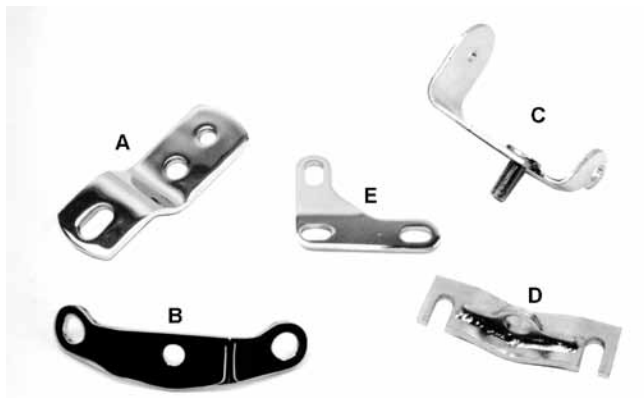

Sportster Top Motor Mount Kits

1957-76 Sportster, chrome plated, sold in 2 and 3 piece kits. OEM#'s (A) 16251-58, (B) 16250-57, (C) 69129-72A.

PCP	Parts	Description
1374	A, B	2 pc 1957-77
1375	A, B, C	3 pc 1957-77
27327	A	1 pc 1957-78 (16251-58)
27334	B	1 pc 1957-84 (16250-57)
1376	B,C,D,E,	4 pc B&E chrome, C&D zinc 1977-81
27321	E	1pc 1979-81 cyl/head to brkt, chrome (16265-76)
27323	E	1 pc 1982-85 up/frt/motor mount (16214-81)



Chrome Front Motor Mounts XL 1984-03

Order top mount cover separately to cover existing mount. Sold in pairs.

3424 Pair (16210-84A, 16212-84)



Limiter Kit FLT 1980-01 and FXR 1982-84

Use this kit to dampen extreme movement on front motor mount cushion.

40116



XL Top Motor Mount

Chrome plated top motor mount and coil bracket replaces the stock item and allows you to use new style Harley 6v and 12v coils. Fits all 1957-78 and 1982-85 XL's.

2064 XL-XLH one piece top mount



XL Rear Motor Mount

2 bolt top style, cast, replacement

PCP	Description
4057	XLH 1967-81, XLCH 1970-81 (16203-67)
4058	XLH 1982-90 (16203-82A)
24092	1954-81 Bolt kit
24093	1982-90 Bolt kit



XL Front Chrome Lower Motor Mount Plates

PCP	Application
1155	1952-81(16210-52A, 16213-52A)
1899	1982-E84 (18256-82)
3424	L1984-03 (16210-84A, 16212-84)
5106	1957-84 Acorn bolt kit

Motor Mount Hardware



2156

Upper & Lower Motor Mount Kit Pre 1970

Complete stock motor mount kit features bolts, castle nuts, cotter pins and heavy duty washers.

Chr	Cad	Parker.	Application
2156	5199	9627	OHV BT 1936-69



5396

BT Upper and Lower Motor Mount Kit 1970-84

Complete stock motor mount kit includes heat treated, plated bolts, locknuts and heavy duty washers.

PCP	Application
5396	Shovelhead 1970-84 chrome
5397	As above cad

XL Front Upper and Lower Motor Mount Kit

Complete stock motor mount kit includes plated bolts, locknuts, washers, spacers and special biter washers. Fits Sportster 1957-85.

9798	Chrome
9799	Cad



Chrome Polished Allen Motor Mount Kits

9926 BT 1970-84



1777

1776

Acorn Motor Mount Kits

PCP	Application
1776	Lower BT 1936-64
1777	Upper BT 1936-64



5106

XL Acorn Motor Mount Kits

PCP	Application
5106	1957-84
1751	Extra-length 1957-84



9797

XL Chrome Polished Allen Motor Mount Kits

PCP	Application
59069	1957-84 Stock Hex
59070	1957-84 8.5" Extra long
9797	1957-85

XL Forward Controls



883-1000-1100-1200 Forward Control Kit

Kit includes chrome brake and shifter assemblies, complete with all necessary brackets, pedals, linkage, o-ring pegs and hardware for installation. Use existing master cylinder for assembly.

90199 Fits 1984-85 4 speed alternator models only

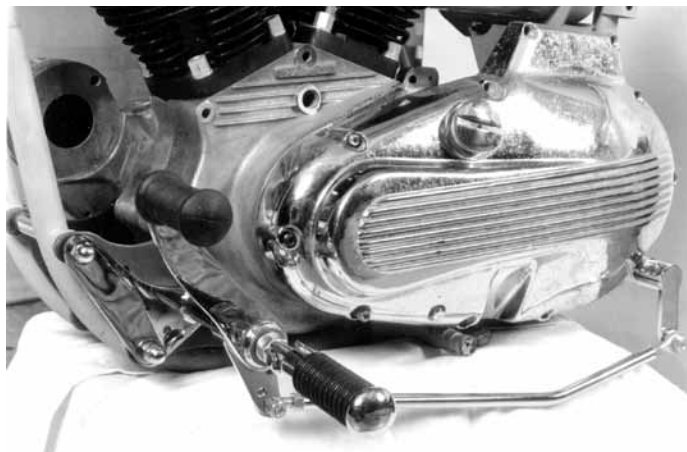

Daniel Boone Forward Control Set

1979-83 models include master cylinder and stainless brake line. Kit includes right brake and left shift.

90198 1979-83

XLH-XLCH Chrome Forward Controls 1977-78

Controls are shipped complete as pictured for right and left sides on 1977-78 models with mechanical brakes.

90316



Forward Control Kits for Sportster® Models

Easy-to-install kits for moving the stock controls to a more comfortable position near the front frame down-tubes. All of the major components of these kits are chrome-plated, and they come complete with rubber-covered brake and shifter toe pegs, and necessary hardware. (imported) **Note: will not work with some stock exhaust.**

90214 Fits 1975-76

90211* Fits 1977-78

90220* Fits 1979-81

Note: Kits require the use of extended motor mount bolts for their installation.

*** Requires modification to stock shifter arm**

BT Forward Controls

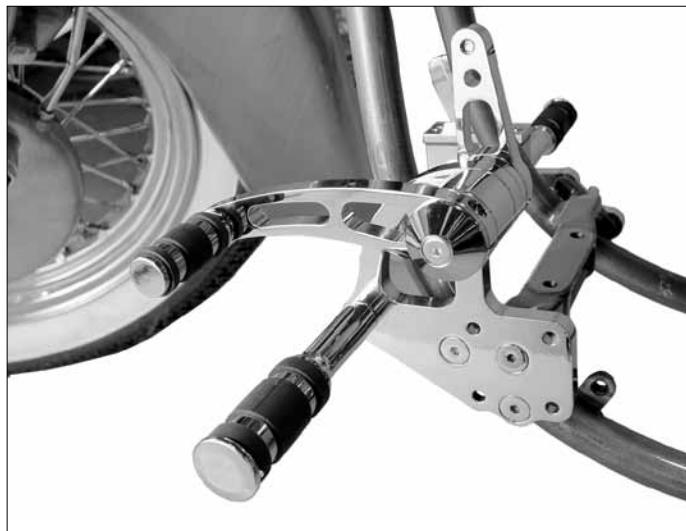
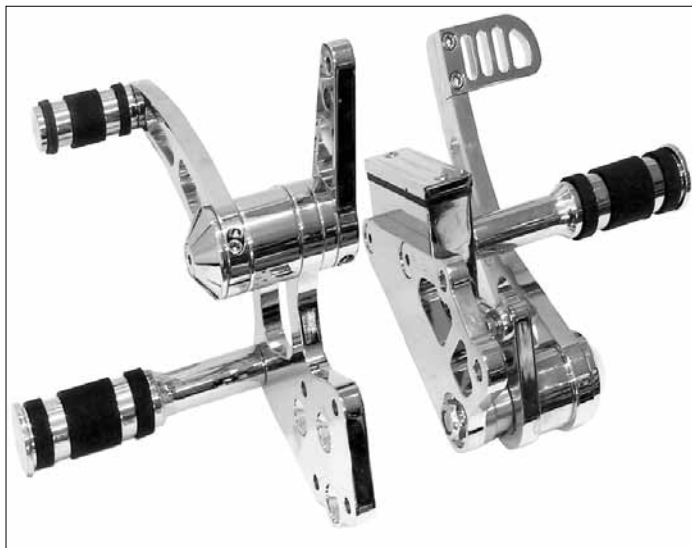

Chrome Billet Forward Control Kit FX, FL

Fits 1958-84 FX, FL and features rubber belted pegs. Includes left and right sides complete with master cylinder. Order shift rod and stainless steel brake lines separately.

PCP Position

59320 Stock

59003 +2"

59321 +3"

Stock Chrome Shift Rods

37214 1952-77 FL

37216 1979-84 FXE

+2" Chrome Shift Rods

59449 1958-78 BT 4 speed ratchet

59006 1979-84 FXE 4 speed

+3" Chrome Shift Rods

59057 1958-78 BT 4 speed ratchet

59006 1979-84 FXE 4 speed

Replacement Hardware

59264 Passenger peg set

59451 Shift lever

73595 Brake plunger

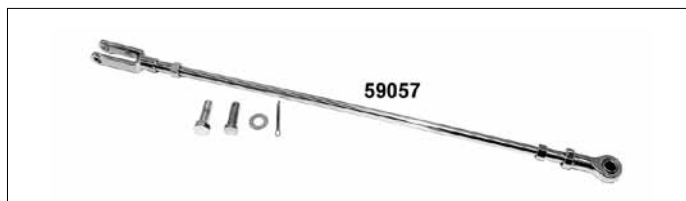
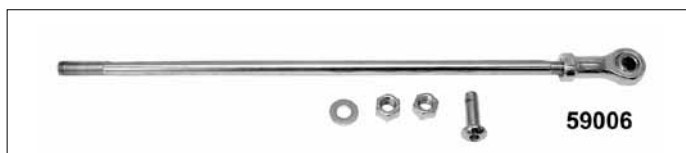

Chrome Heim Joints

Heim joints have a variety of uses and are especially useful for custom shift and brake linkage creation. The 5/16" joints are available with left or right hand threads. USA made.

PCP Size

71009 1/4" x 1/4-28 female

71010 5/16" x 5/16-24 male

71011 5/16" x 5/16-24 female

71012 5/16" x 5/16-24 male (left hand thread)

71015 3/8" x 3/8-24 female



Billet Chrome Rear Passenger Peg Set

Pegs feature 3 rubber band inset to match billet forward controls.

59264

FXR Forward Controls

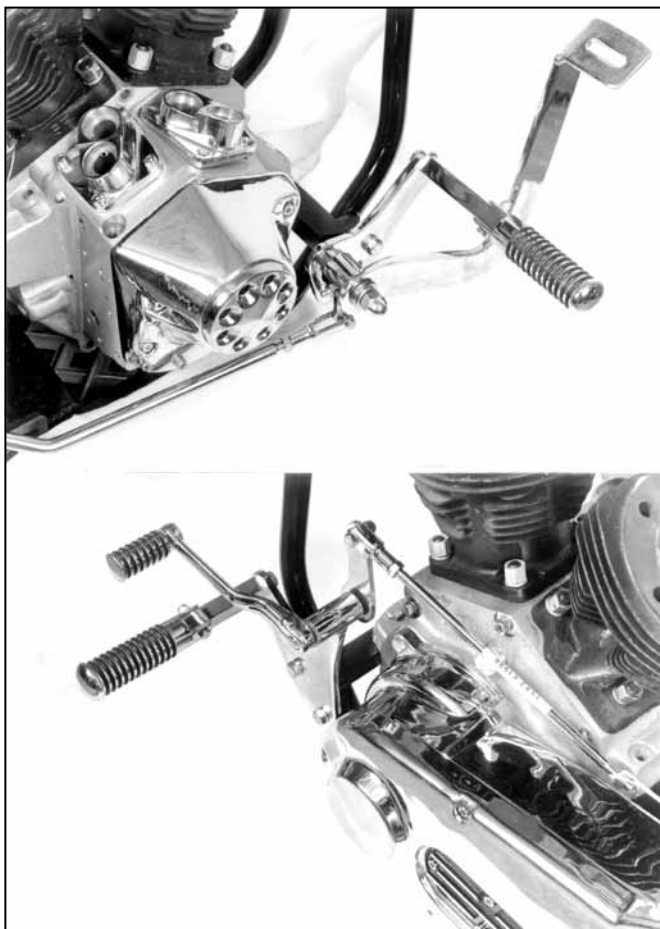

FXR-FXRS Forward Control Sets

All 5 Speed FXR-FXRS series Shovel or Evo powered 1982-on. Installation does not require the primary cover to be removed. All parts are chromed and the footpegs provided are "O" ring style. Does not fit Dyna Glide.

4703 1982-94 FXR

1982-on FXR Forward Control Set

Complete set brake & shifter units are a replica of the comfortable FXST style, which has pegs in full forward position, features one piece brake rod which adapts directly to stock master cylinder, no need to relocate master cylinder on all 1982 & later FXR-FXRS-FXRT, also 1985 FXS-FXE. Chrome cover included to cap shifter shaft after installation.

PCP	Years	Type
90309	1982-E87	Set
6462	1982-85	Shift Side
59064	1982-E87	Brake side
59066		Clevis brake side



FXR Passenger Footrest Comfort Kit

Chrome plated, super strong 3/8" steel plates machined to ideally relocate the passenger pegs on all FXR Series Harley Davidson models. The pegs are moved several inches higher and farther forward, for improved passenger comfort. Complete with chrome plated hardware, the brackets can be used with stock footpegs or with any one of 1/2" stud mount footpeg sets.

4513 FXR footrest kit (pegs not included)

FXR Shift Shaft Cover

Chrome acorn style had 1/2" I.D. to fit over unused shifter shaft in primary cover when installing forward controls.

12609 Each



FXR Billet Forward Control Kit 1982-94

Kit includes master cylinder.
59327



FXST Style Brake Control



1979-84 FLH Chrome Brake Kit

This kit includes chrome pedal, chrome plate with front floorboard bracket, plunger, spring, and stud. Master cylinder must be ordered separately.

- 90162** Chrome kit, less master cylinder
- 3964** Chrome alloy master cylinder (Kelsey Hayes style)
- 46780** Plain alloy master cylinder (Kelsey Hayes style)
- 4700** Rear zinc floorboard bracket 1970-84 (50655-70)

FXST Replica Forward Brake Control

For use on all Big Twins 1970-on with Shovel engines, equipped with hydraulic disc or drum brakes. Designed after the 1984-on FXST which places the driver peg in back of the brake pedal, so the brake is easier to operate from this comfortable position. Redesigned to accept a Wagner or Kelsey-Hayes style master cylinder or the GMA version masters. Hardware includes linkage, pedal mount plate, rubber covered foot peg. This kit is the exact compliment to our shifter kits 6309, 6461, 6462, and 6463 and when used with one of these kits, places the pegs in a forward and raised position parallel to each other.

PCP Description

- 6309** Complete kit with Kelsey type master cylinder
 - 6308** Complete kit with Wagner type master cylinder
- Note: Kits **6308** and **6309** use Russel Stainless Lines **#49800** front and **#49802** from junction to rear caliper. Use tee **3370**



Brake Pedal Pad

Features chrome die cast backing for rubber insert pad. Replaces OEM pad on 1983-86 FXWG, bolts on!

- 46801** FL 1965-84, FLT 1980-83



Chrome Forward Brake Pedal

Pedal provides driver with better access to pedal from floorboard.

- 46804** FLH 1979-84 (use stock pad)

FXST Style Shifter



BT Chrome Forward Control Kit 1958-86

Control kit consists of both shift and brake sides including: a 3/4" bore chrome Kelsey Hayes style master cylinder, o-ring pegs (but can be replaced with other styles of clevis mount pegs), a universal nylon brake line kit, 4 and 5 speed shift rods are also included and chrome mounting hardware.

90318

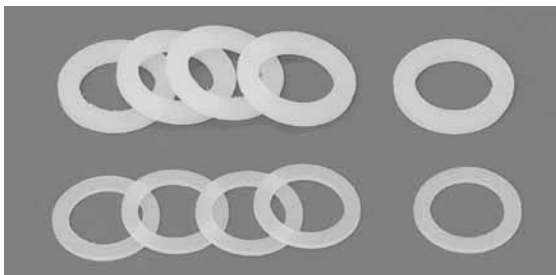

Nylon Shifter Washers

Includes 2 nylon washers that reduce vibration at the inner shifter arm and pedal.

20503 10 pack

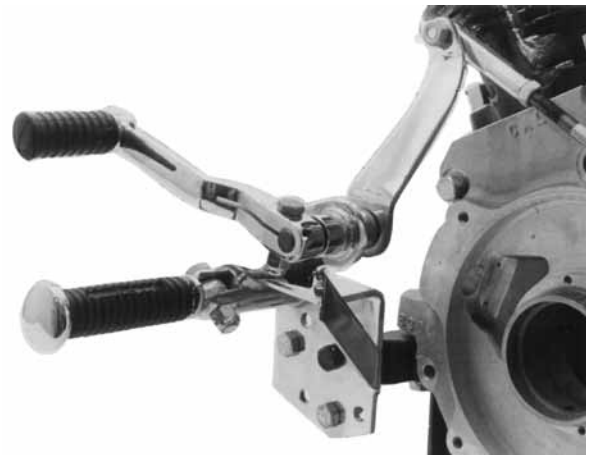
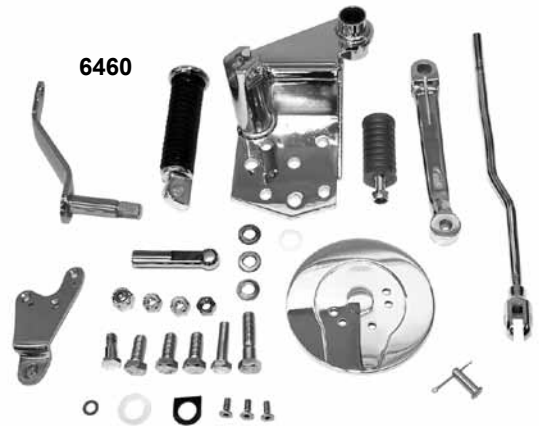

FXST Replica Forward Shifter Kit

Complete kit with all hardware necessary for installation on 4-speed models 1952-84 and 1981-on 5-speed Big Twin models. Use in conjunction with our FXST replica controls listed on the opposite page, as all kits place pegs in a forward position parallel to the peg on brake side. Foot rests on peg while shifting for added comfort. This is an exact stock replacement in chrome for the 1980-85 FXWG. Kit includes chrome heavy duty shifter bracket, inner shifter lever, rod, rubber shift peg and foot peg,

PCP Years/Model

- | | |
|-------------|--|
| 6460 | 1952-78 FLH Ratchet top 4-speed
1971-73 FX-FXE |
| 6462 | 1979-84 FXE Rotary top 4-Speed
1981-on FXR-FXS-FXRS 5-speed |



Grease Elimination Spacer

Stepped design spacer with o-ring replace stock spacer (OEM 5702) on shift shaft FLT 1980-on.

11824

Forward Controls



Early Type 1958-69 Forward Hydraulic Brake Kit

Includes all parts illustrated, exact OEM replacement for flat side motors 1958-69, or for use on cone motors with an outside frame pipe, includes either cast iron chrome or plain master cylinder.

6315 With chrome master cylinder

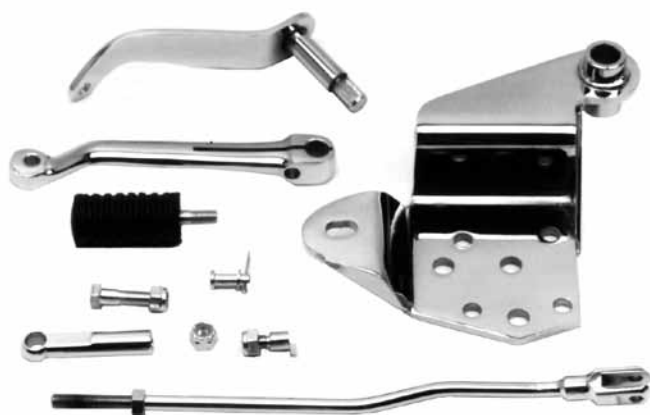

Original Equipment Style Forward Shift Control Kits for Big Twins

These chrome-plated OEM-style replacement forward control kits (footpegs not included) fit all 4-speed Big Twins from 1958-E79. These kits will work with OEM style floorboards or 3/8" stud mount custom footpegs. This features a splined shift lever and shift arm rubber shift peg, and a specially braced shifter backing plate. Mounting hardware not included.

Forward Shifter Kit

90213 Fits all 4-speed FL's from 1952-1985

Forward Shifter Control

Original FLH type shifter kits allow the use of foot pegs or floorboards. Order complimenting forward brake controls. Units allow 1 down and 3 up shifting pattern. The 6318 and 90215 kits include proper ratchet arm and dust cover. All other kits attach to existing components on shifter mechanism. All components are made and chromed in U.S.A.

PCP Years/Model

6318	1952-79 FL-FLH 4-speed
6319	1979-84 FLH 4-speed, 1980-85 FXWG 4-speed
90215	1974-78 FXE 4-speed
90216	1979-on FX-FXE 4 speed, 1981-on FXR 5 speed

Note: on FLH models 1979-83 rotary trans tops have the down turned shifter top arm. OEM: 33177-79, PC# **36128** or **4787**. Check cycle on your factory parts book for correct application.

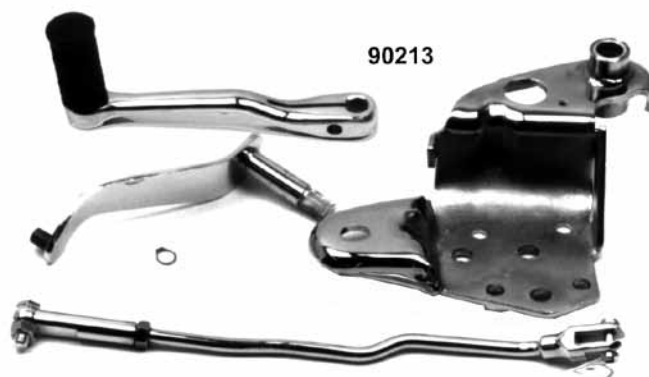

Forward Brake Controls

Our original forward control assemblies equips all Big Twins with hydraulic brakes and powered by 1970-on Shovel engines. Floorboards can be fitted to our Wagner style kit **6316**. Mounting hardware not included.

PCP Description

6316 Wagner with chrome master cylinder 1970-78

6317 Kelsey-Hayes with chrome master cylinder

Note: For kit **6316** use front line **49800** for disc brake models and tee **3370**.

Forward Controls



Shifter Pegs

PCP	Style	Type
39019	O-Ring	Rotating
39017	Railer	Chrome with rubber
39024	Cats Paw	Chrome with rubber, 3/8" stud
39025	Cats Paw	Chrome with rubber, 5/8" stud
39018	Cats Paw	Chrome with rubber 1" longer
1402	O-Ring	Chrome with o-ring 1/2" longer
1147	Stock	Black with 1/2" stud
5432	Stock	Black with 3/4" stud
5433	Stock	White with 3/4" stud



Adjustable Highway Peg Kit

Fits XL late 1985-03 with alternator. Kit includes: right and left chrome supports with Cats Paw pegs that adjust into three height positions; to fit with engine guard kit.

39240 49503-96

Complete Brake & Shifter Kits

These kits are fully chrome plated, and fit all hydraulic brake models with disc or drum brakes, for rigid or swing arm frames. Kits use a Kelsey type master cylinder (master cylinders is NOT INCLUDED with kits). Kelsey style master cylinder from Preston is #3964. NOTE: #90300 is for mechanical brakes on rigid 74 frames 1936-57 type. Each kit's shifter parts include correct linkage for either (1952-78) ratchet top, or rotary top (1979-84 4 speed), or 1981-85 5 speed as noted. KITS INCLUDE BOTH LEFT & RIGHT SIDES.

PCP	Year	Model
90301	1952-79	FL-FX 4 speed with ratchet lid
90302	1979-84	FLH-FXWG 4 speed w/rotary



Chrome 'D' Shaped Floorboards

Feature ISO design with rubber inserts in stainless steel grid. Pair.

PCP	Year	Model
39083	1940-85	FL-FLH
39084	1979-on	FLT

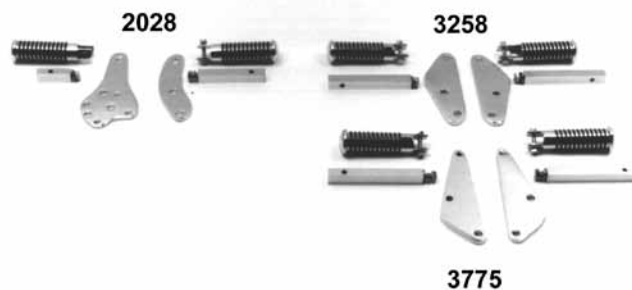

Motor Mount Pegs for Harley

Fold-up peg chrome footrests for comfortable cruising.

Big Twin, 4-speed models 1958-84 (except FXST).

Note: Models without the right-side frame mounting tab from factory must install our weld-on frame tab.

2028 O-ring style

5-speed FXR 1982-94

3258 O-ring style

Sportster 1982-83 (except models with alternator)

3775 O-ring style

Floorboards

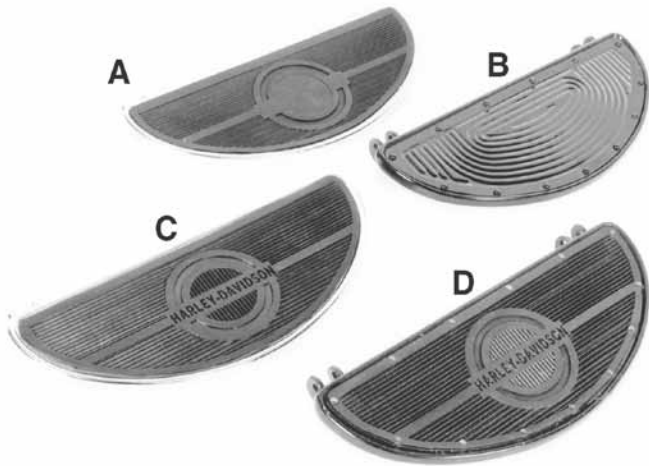

Oval Style Floorboards

Designed to fit the stock mounting brackets on FL 1940-84 and 45" models 1970-73. Replaces 50603-40.

PCP Application

- 19854** (A) Black with rubber mats
- 2431** (A) Chrome with rubber mats
- 19855** (B) Black with metal top
- 19856** (C) Chrome with rubber H-D logo mats
- 19857** (D) Black with H-D logo mats



Oval Chrome Metal Floorboard Insert

Fits 1940-84 FL and 1940-73 45 models.

59759



Black Floorboards with Pads 1940-84

19798 50603-40BR (pair)



39062

Ribbed Oval Chrome Custom Floorboards

Includes a pair of floorboards, chrome covers, rubber pads and vibration dampeners.

PCP Fit

39062 FL 4 speed 1966-84



BT Replica Floorboard Mount Bracket Kit

Kit includes 4 brackets and related hardware.

19520 1936-54 Rigid (parkerized)

19521 1955-57 Rigid

19522 1958-64 Swing arm

Floorboard Extension Pads

Pads clamp on to 1914-65 style floorboards. Replaces 52654-33, 52655-33, 52668-33.

19444 Parkerized

19445 Chrome

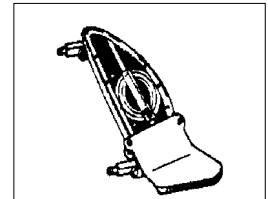

Footboard Mounting Kit

Parkerized studs, washers and nuts used to mount footboards on 1936-54 Big Twins.

72675



Floorboards

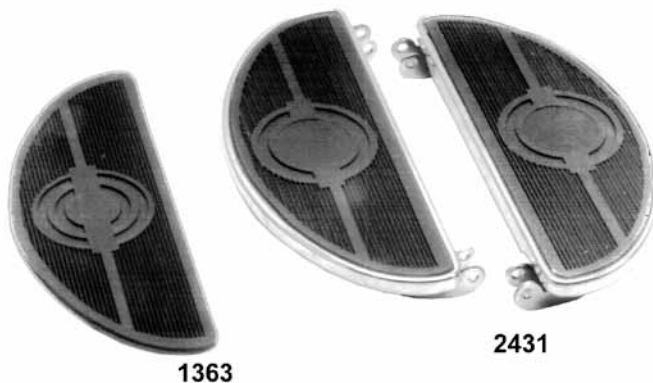
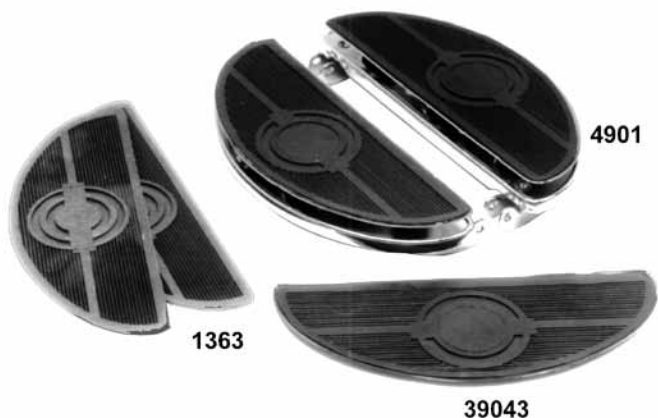

Oval 'Shaker' Floorboards (4-speed) 1940-84

Custom "Shaker" floorboards replace stock rigid boards as used until 1965. These feature the added comfort of the rubber pads floating on rubber cushions just like late-model floorboards.

Note: Not designed for foot clutch models as floorboards will reduce the amount of travel available for the foot clutch rocker pedal. Custom modifications may be required on these models.

PCP	Fits
4901	Floorboard set
39043	Replacement floorboard upper plate and pad (each)
1363	Replacement oval pads (50614-40T) (pair)
4701	Replacement bumpers (50620-74) (set of 8)

Original-Style Oval Floorboards

These original style floorboards fit the stock mounting brackets on all FL 4 speeds 1940-84. If you no longer have your stock mounting brackets, replacement bracket kits are available separately.

PCP	Fits
2431	Floorboard set (50603-40)
1363	Replacement pads (50614-40T) (pair)
2432	BT 1936-64 mounting kit
2435	BT 1966-82 mounting kit



Adjustable Floorboard Kits

The design of these adjustable floorboard kits provide the rider with a position choice. These kits allow a full seven inches of front-rear adjustment. Angle and height adjustment are also adjustable. Kits were designed to fit all FXWG 1980-86. They may be installed on any motorcycle with clevis-style footpeg mounts. Hardware and instructions included.

39050	Kit with "D" style shaker floorboards
39051	Kit with oval shaker floorboards



Oval Floorboard Rubbers

Fits 1940-65 FL, FLH and replacement type floorboards. Pair.
23023 50614-40T (pair)



Footboard Hinge Bolt Kit

Chrome plated reproduction of special shoulder bolt to replace 50635-82. Fits all 1982-on FL and FX with footboards. Complete with chrome washers and locknuts.
72125

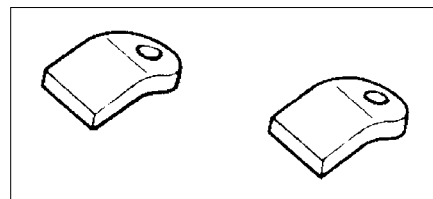

Weld On Frame Floorboard Tab Set

Works on all stock or custom frames when floorboards are used.
3778 Pair

Floorboards



Late Style Floorboards

These floorboards fit 4-speed FL models from 1966-84 and feature chrome-plating and a raised floorboard pad with anti-vibration rubber bumpers as on stock. Can also be used on early 'tin' primary models when PC #2432 bracket kit is used.

PCP Description

- 2434** Floorboard set (50603-74) 1974-85
- 1224** Replacement pads (50614-66) (pair) 1966-on
- 4701** Replacement bumpers (50620-74) (set of 8)
- 39046** Replacement floorboard upper plate including pad (each) 1974-85
- 2433** Chrome floorboards with black pads (50603-66)
- 1224** Black rubber floorboard pads 1966-on



Shaker Late Model Floorboards

We offer three styles to choose from. They fit all 5-speed FLT models from 1980-on. The oval 'shaker' sets have the mounting brackets offset from the centre of the floorboards. Depending on which way they're installed, you'll end up with your feet approximately 1" further ahead of or behind the stock position. This adjustment permits your choice of foot placement. The rectangular and oval 'shaker' floorboards will replace stock items.

Floorboard Sets

PCP Description

- 3782** Rectangular 'shaker' floorboard set 1979-on (50621-79A)
- 39049** Oval as above (for nostalgic look) (50599-89T)

Replacement Parts

- 1224** Rectangular pads 1966-on (50614-40T) (pair)
- 1363** Oval pads (50614-40T) (pair)
- 4701** 50620-74 Replacement bumpers (set of 8)
- 39046** Rectangular floorboard upper plate including pad FL 1974-84 (each)
- 39043** Oval floorboard upper plate including pad (each)



FX-FXR Rear Floorboard Set

Chrome mini boards feature spade type mounting studs, with 2 position angle hole. Studs mount to all applications that originally fitted with 49117-77 peg.

39052

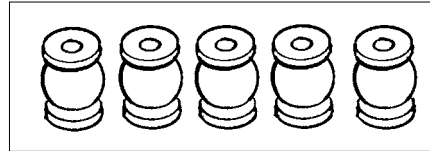

Late Style Bumper Set

PCP Description

- 4701** Set of 8 (50620-74)

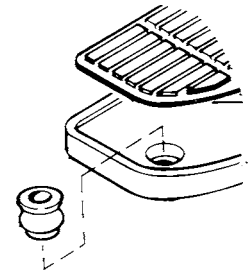

Passenger Floorboards

Add these floorboards for added passenger comfort on long trips. Chrome plated finish with non-slip ribbed rubber surface, reducing fatigue and vibration discomfort. Set of floorboards comes complete with necessary mounting parts, bolts, nuts, spacers and brackets. Fits all FLH's and FLT's.

2436



Passenger Floorboards

These chrome-plated floorboards provide a quick method of providing additional comfort for your passenger. Bolting on in minutes, these floorboards will fit Big Twin 4 speed frames 1958-86. They will not work on models with a kickstart, as they interfere with the kickarm.

2902 Sold in pairs

Floorboard Hardware



Right Rear Mount Bracket

1970-84 foot board mount stud replaces 50655-70, zinc plated.
4700



Floorboard bracket 1970-84

This bracket must be used to replace the right side factory floorboard mount if you want to retain floorboards on an FLH when using muffler pipes, drag pipes.

2066



Footboard Hinge Bolt Kit

Cad	Parker.	Application
5364	9685	Hex all 1941-81
8774	9722	Buddy foot rest bolt kit 1941-64
	9886	Slotted 1914-40

Footboard Stud Mounting Kit

Parkerized duplicates of original fasteners used to mount footboard studs.

9905	BT 1936-57 (shown)
9906	Servicar & 45 Solo 1935-on

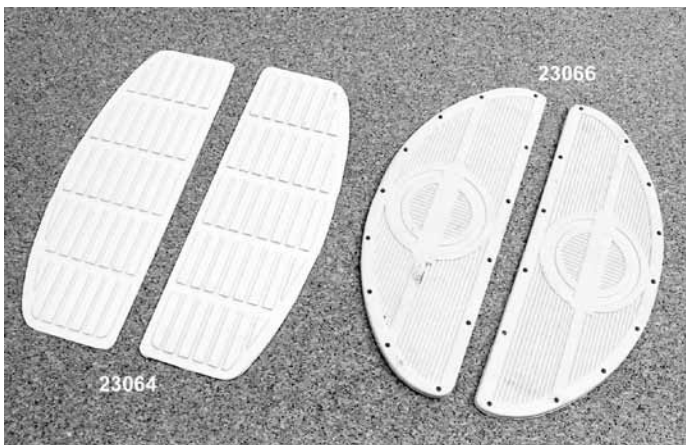
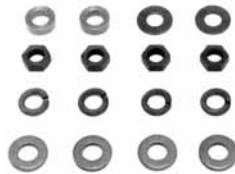

Ivory Floorboard Pads

23064	Rectangular 1966-on (pair)
23066	Oval 1940-65 (pair)



2435

2432

Aluminum Primary Floorboard Mounting Kit

Fits all Big Twins 1936-on. Includes all the correct studs, washer and nuts.

2435	1966-82 (aluminum primary)
2432	1936-64 (tin primary)



Floor Board Mount Kit

Complete kit for aluminum primary models 1965-84 FL-FX, when using custom pipes, this includes the extended front floorboard bracket for the needed clearance.

5787



Footboard Hinge Bolt- Buddy Footrest Bolt Kit

Reproduction of special shoulder bolts, pins and bushings used to mount footboards and buddy footrest on all 1941-64.

PCP	Description
8774	Cad
9722	Parkerized

Floorboard Rivets 1914-65

10006 50616-14 (25 pack)



Foot Pegs



Krome-Railers

These are designed with chrome body with rubber "rails" inserted for good grip. Peg diameter is mid size between small and large diameter pegs.

- 51204** Handle bar grips 1973-95
- 39014** Male pegs, large, FXR driver (1-1/2" o.d.)
- 39015** Male pegs (1-1/4" o.d.) small
- 39016** Female pegs, large driver
- 39017** Shift peg
- 39013** Female pegs for 5/8" square bars
- 39201** Kicker pedal



Rubber Rider Footpegs

Pegs for FX 1973-84 feature zinc ends.

- 39111** Pair (50939-52)



Extended Pegs

1" longer than stock made yoke end pegs, fits FX & FXST passenger pegs and FXWG driver peg. Sold in pairs.

- PCP Style**
- 39140** Rubber with chrome caps
- 39141** O-Ring style
- 39034** Cats Paw ISO style with yokes
- 39018** Extended cats paw shifter (each)



Original Style Footrests

For use on 1" diameter safety bars or frames.

- 19596** 49100-58 (pair)



Motor Mount Pegs for FXE

Chrome highway pegs. These kits provide an additional foot peg set well forward of the stock location, creating a much more comfortable riding position. Use on all 1971-84 FX, FXE and FXS when forward mount kickstand is desired.

- PCP Peg Style**
- 39155** O-ring
- 39157** Cats Paw

Chrome End Caps

PCP End Caps (pair)

- 424** Fits #39111 and #1149



O-Ring/Cats Paw Pegs



Kick Pedal and Shift Pegs

- PCP Type/Model**
- 1400** Flat kicker pedal (50908-88T) (each)
 - 1401** Kicker pedal all (50902-84T) (each)
 - 1402** O-Ring shift peg 1/2" long (34631-84T) (each)



Driver Pegs (Pairs)

- 765** FX-XL Large driver peg, female (52651-85T)
- 39000** FXR Large driver peg, male end 82-90 (50913-89T)



Custom Pegs

- 763** Clamp on 1-1/4" (pair)
- 764** 3/8" Stud mount pegs (pair)
- 39001** Pegs only, fits 5/8" square blocks



Passenger Pegs

- 4709** FX-XL rear passenger pegs, hiway-bar male end, small diameter (50901-84T) (pair)
- 39141** Extended, as above, 1 1/2" longer

Replacement O-Rings for Pegs (10 Packs)

- 2466** O-Rings for small pegs (49031-84T)
- 2464** O-Rings for large pegs (49028-85T)
- 2467** O-Rings for flat kick pedal (49029-85T)
- 2465** O-Rings for shifter peg (49030-84T)



Cats Paw Pegs

Unique soft rubber pad is an inserted cleat isolastically mounted on chrome Allen socket bolt and yoke stem. Vibration is reduced. Pegs sold in pairs and matching shifter sold each.

- | PCP # | Description | PCP # | Description |
|--------------|--|--------------|--|
| 39020 | A Large driver female end 1952-on FX & Sportster | 39032 | J Kicker pedal |
| 39026 | E Mount yoke for above, female | 39022 | B 5/8" Female type for custom hiway pegs |
| 39021 | H Large driver, male FXR 1982-on | 39037 | C As above, clamp-on set |
| 39028 | M Male yokes for above pegs | 39027 | D 5/8" Female yokes only for above peg |
| 39023 | I Passenger, rear 1973-on FX-XL-FXWG front 1981-on male end, OEM type hiway pegs | 39024 | K Shifter peg 3/8" stud |
| 39034 | G Peg set as above pegs 1" extended | 39025 | K Shifter peg 5/8" stud |
| 39028 | M Stock size mount yokes for above, male | 39018 | Shifter peg 1" longer |
| 39035 | L 1" Extended male yokes, above | 39030 | F Rubber only for #39020 and #39021 (8 pk) |
| | | 39029 | O Rubber only for #39022 and #39023 (8 pk) |
| | | 39031 | N Rubber only #39025 (3 pk) |

Foot Pegs



Stock Replacement Large Diameter Footpeg

Steel peg set with rubber covers. Fits FL models 1941-84, FX models 1971-85 and XL models 1954-84.

PCP Item

- 3246** Stock type replacement footpeg set
- 1149** Replacement footpeg rubbers only (50940-52) (pair)
- 23089** As above, white (pair)

Stock Replacement Footpeg Rubber for FXR Models

Footpeg rubbers only. Fits all FXR models 1982-on. Replaces OEM 50646-82. Set of 2

Note: Must be glued to footpeg shank

6626

Stock Replacement Passenger Peg/Kickstart Rubber

Footpeg rubber only. Small diameter replacement rubber cover used on passenger pegs, highway bars and kick levers. Replaces OEM 33189-63. Sold each

3902 Black

Stock Replacement Shifter Pegs

PCP Item

- 1147** Rubber shifter peg (1/2" long stud) (34611-65T)
- 2443** White (as above) (34609-65)
- 5432** Rubber shifter peg (3/4" long stud) (34609-52T)
- 5433** White (as above)



Chrome Mustache Bars

Bar includes a Cat Paw peg set and should not be used with a front engine bar.

39080 FX-FL 1958-84



7A-40



Stock Type Passenger Pegs

Stock replacement FX style passenger pegs 1/2 x 20. Sold in pairs with chrome plated ends. OEM #50907-69A.

- 1484** Peg set
- 4706** Rubber only (33189-63) (pair)

Stock Style Replacement Peg

Without blocks. Replaces OEM #49117-77

- 1483** Stock peg (pair)

Foot Peg Mounting Yokes

Chrome plated. Mounts are available in 1/2" fine thread mounting holes. Sold in pairs

PCP	Thread	Length
3779	1/2"	1" (50900-72)
39126	3/8"	1"
39127	1/2" x 13	1"
39128	Thru hole 3/8"	1-7/8" (50942-00)



Chrome Cap Shifter Peg

Replacement shifter peg with chrome end cap pressed over rubber peg. Sold each

3247

Chrome Cap Pegs

Replacement XL-FX drive peg with chrome end cap and chrome mounting block.

- 3248** Driver (pair)

FX, XL Kick Pedal

Black chrome end cap (33178-63)

3250

Foot Pegs



Spoon Style Clamp-on Footpeg Sets

Chrome plated peg with zinc clamps and hardware have a folding type mount block.

59551

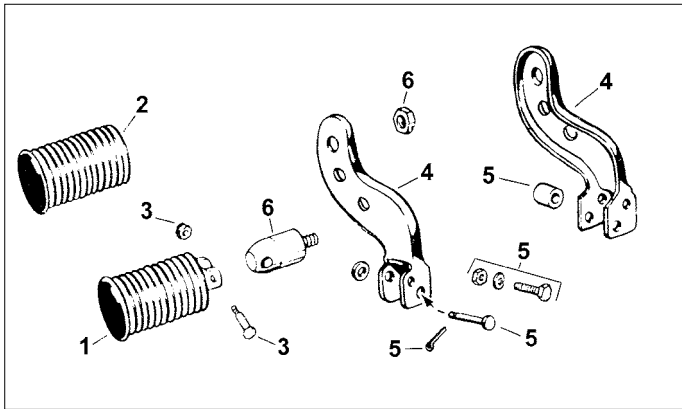
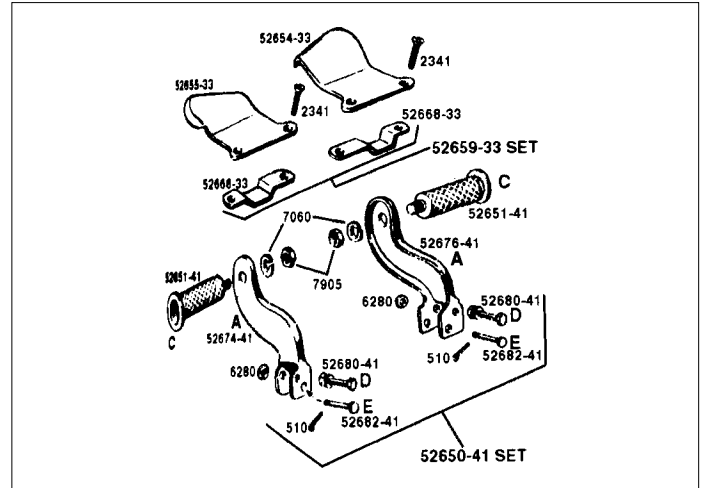

Footrests 1941-64

#	PCP	Description
1	3246	Footrest, chrome (50939-52) (pr)
	39111	As above, zinc
	3248	As above, w/chrome mounts & ends
2	1149	Footrest rubber (50940-52) (pair)
3	4381	Chrome bolt, passenger footrest 1952-on (50970-52) (4 pc)
4	19439	Bracket set, right & left, chrome (52674-41, 52676-41)
	19440	As above, black
5	9722	Bolt, footrest bracket, parkerized (52680-41) (18 pc)
6	3783	1/2" Stud, footrest support, zinc (52683-74) (pr)
	10892	As above, chrome

Buddy Seat Foot Rest Brackets

Brackets mount to existing floorboard brackets on BT 1936-64 models. Replaces 52674-41 and 52676-41. Pair.

PCP Description

19439	Chrome brackets only
19440	Black brackets only
8774	Bolt set, cadmium
9722	Bolt set, parkerized
19441	Peg set with rubbers, zinc
19442	Peg set with rubbers, chrome
19443	Rubbers only 1941-54

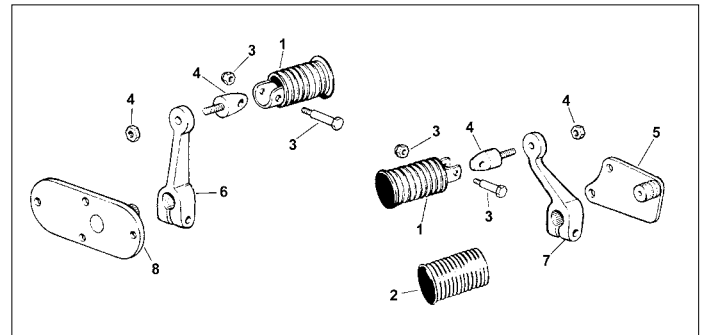

BT Footrests 1965-84

#	PCP	Description
1	3246	Footrests, chrome (50939-52) (pr)
	39111	As above, zinc
	3248	As above, w/chrome mounts & ends
2	1149	Black footrest rubber (50940-52) (pair)
3	4381	50970-52 Passenger bolt kit, chrome 1952-on (50970-52) (4 pc)
	4382	FL-FX Passenger bolt kit, chrome 1969-on (4721) (4 pc)
4	3781	3/8 x 24" Stud, footrest, zinc (50973-65) (pr)
	10891	As above, chrome
5	21004	Right footrest bracket, chrome (52688-65)
6	5788	Left footrest support (straight), chrome (52698-65)
7	21007	Right footrest support splined (offset), chrome (52700-65)
8	21005	Chrome inspection cover w/spline footpeg support (60574-65)
	10305	Key for #21005 (23985-18) (10pk)

Peg Mounts



Late XL Foot Rest Support Bars

Right and left support bar set replaces OEM #49118-77 and use on all XL's. With welded square insert on motor mount plate. Chrome plated.

- 4705** Bar set (49106-78T)
- 1483** Peg set (49117-77)



Chrome Foot Rest Support Bracket Kit

Fits XL's 1972-on, FX 1972-81 FXRS (50900-72). 1/2" Mount bolts. Pair.

3779

Weld On Foot Peg Mounts

Stock blocks can be welded to 1977 & earlier frames to use the stock FXE mounts, or be used to raise peg position.

- 4559** Weld on peg mount (pair)



Chrome Rear Footrest Bracket Set

Lustrous chrome on strong 1/4" steel plates. Direct replacement for the rear footrest brackets on Harley FX, 4-speed models thru 1981. Also can be used to replace the 1982 and later one-piece welded and stamped rear footrest bracket, as well as the larger aluminum adjustable rear footrest brackets used on 4-speed FL models 1977 thru 1984.

- 2473** Left and right brackets only
- 1226** Bracket set complete with footrest supports and footrest mounting hardware



Weld-On Frame Tab (R/Side)

Forward control brake and floorboard mounting tab. Use on stock FX or custom frames. Drilled and tapped 3/8" thick stamped steel.

4550

Peg Mounts



Sportster Driver Footpeg Support Mounts

Splined type, less pegs fit 1952-74. Replaces 50948-71 left, 50949-67 right. Use with large female type driver pegs.

PCP	Finish
27174	Zinc
27175	Chrome



Chrome 5/8" Footpeg Bars

These footpeg bars include a 3/8"-16 x 3/4" grade 5 chrome-plated bolt and lockwasher, and are commonly used as replacements for broken motor mount pegs.

39100	2" long (each)
39101	4" long (each)
39102	5" long (each)
39105	3" long (pair)



Chrome Adjustable Foot Peg Mount Kits

Pegs can be rotated to different positions using the detent locking system and the yoke provided fits into the stock female footpeg clevis on models that accept a male end peg. Order pegs separately.

39115 FXR rear 1982-on



Chrome 3" Footrest Support Bar

Replaces 49127-77, set of 2 hiway bars on FX-FXRS, 1977-on. Heavy duty with 7/16-14 mounting studs.

4707



Rear Peg Relocation Brackets

Use these chrome brackets to place pegs in a more comfortable position.

5789 1973-84 FXE



XL Footpeg Spring

Fits right side 1954-78 rear passenger peg.

13096 Pair (52697-59)

Foot Rest Supports and Studs XL 1977-on

PCP	Application
3140	Left support 1977-85 (50948-75)
10823	Left stud 1977-85 (24752-75)
27226	Right support 1977-79 (50949-75)
10835	Right stud 1977-79 (24751-75)
10908	Right pivot stud 1980-90 (42441-80)
27013	Right M/cyl. support bracket 1983-90 (34909-83)

Peg Mounts



BT Transmission Mount Passenger Peg Brackets

Fits Big Twins with rigid frame, use with any 3/8" stud-mount footpeg 1936-57.

2476

Chrome Passenger Peg Mount

3784 Sportsters with swing arm frames 1957-78, uses large driver pegs (52702-59A)

39130 XL 1982-90, uses small male pegs

39131 XL 1957-81 except 1979, uses small male pegs

Footpeg Spring

Fits right side rear passenger on 1954-78 models

13096 Pair (52697-59)



39107

39106

39108

FLH Passenger Peg Brackets 1977-84

These brackets are fully adjustable and they fit FLH & FXE 1977-84 4-speeds.

39106 Right, chrome (52686-77A)

39107 Left, chrome (52690-77A)

39108 Pair, chrome (52686-77A, 52690-77A)

39109 Pair, polished



Passenger Peg Mounts FXE 1973-84

Replaces stock passenger peg mounts and elevates peg position. Ideal for use with custom exhaust. Chrome plated.

5789



Bullet-Style Footpeg Supports

3/8"-24 Stud

Fits FL models 1965-84 and FX models 1971-85.

PCP Description

3781 Zinc plated (50973-65) (pair)

10891 Chromed (pair)

1/2"-20 Stud

Fits FL models 1941-64 and FX models 1971-72.

3783 Zinc plated (52683-74) (pair)

10892 Chrome (pair)

Foot Peg Mounting Shoulder Bolt & Nut Kit

Chrome plated custom shoulder bolts and locknuts to mount driver and passenger pegs on the following Harleys:

4381 FX, XL Driver, FL passenger 1952-68 (50970-52)

9965 Cad plated, as above

4382 FX, XL Passenger 1969-on (4721)

9966 Zinc plated, as above



Footpeg Mounting Shoulder Bolt and Nut Kit

Chrome plated low head socket cap screws add a custom look to all driver and/or passenger pegs on 1969-on FL, FX, XL. Replaces OEM 4721.

72048



Crane Sure Foot Stand

Keeps kickstand from sinking into soft terrain and possibly falling over. Just throw the sure foot on the ground and position your bike so the kickstand fits into the alignment grooves.

34599