

# Section 12A

## Belt Drive & Primary

Belts .....	2
Belt Drives .....	5-7
BDL.....	2-6
Primo .....	7
Belt & Chain Guards .....	33-35
Chain .....	30-31
Chain Adjusters .....	30-33,36
Compensating Sprockets/Kits.....	26,31
Derby & Inspect. Covers ....	12-14,20-21
<b>Primary</b>	
Inner, Big Twin .....	16-22
Outer, Big Twin .....	10-12,21
Sportster .....	25-25
Pulleys .....	7,9
Pulley Covers .....	9
Sprockets .....	26-29

# Replacement Belts

**Note:**  
The replacement belts offered for sale on this page have no warranty whatsoever.

## 8mm Rubber Primary Belts

Bullseye belts are about .020 longer.

PCP	Size	Teeth	F/R Pulley
42059	8mm x 42mm	130	48-68 Kevlar
42060	8mm 1-3/4"	132	48-72
42062	8mm x 42mm	138	45-68 Kevlar (1-3/4")
42064	8mm x 38mm	138	45-68 Kevlar
42065	8mm 1-3/4"	141	47-72
42066	8mm 1-5/8"	132	48-72
42067	8mm 1-5/8"	141	47-72
42089	8mm 3"	132	44-76 Bullseye
42068	8mm 3"	141	47-72
42069	8mm 3"	132	48-72
3204	8.07mm 1-1/2"	132	41-61
42090	8mm 1-1/2"	132	41-61 Kevlar
3206	8mm 1-1/2"	132	41-61, 39-62, Bullseye
3207	8mm 1-1/2"	144	47-76
42092	8mm 1-1/2"	144	As above, Kevlar
3208	8mm 2"	144	47-76 2T & 2S
3209	8mm 3"	144	47-76 3T & 3S
42086	8mm 3"	140	
42087	8mm 4"	140	
3202	8mm 1-1/2"	117	45-76 Sporster
3203	8mm 1-3/4"	117	45-76 Sportster
42056	8.07mm 1-1/2"	132	Kevlar
42085	8.07mm 1-3/4"	132	Kevlar
42057	8.07mm 3"	132	Kevlar



## Panther Rubber Racing Belts

42052	8mm 3"	144	Panther
42053	8mm 3"	140	Panther
42054	8mm 3"	130	Panther
42055	8mm 3"	120	Panther

## Belt Tension Gauge

Gauge is designed to aid in properly adjusting belt tension on models with a secondary drive belt.

26016

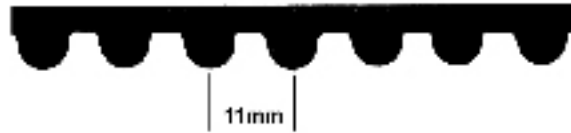

## 11mm Rubber Primary Belts

PCP	Size	Teeth	F/R Pulley
3199	11mm 1-1/2"	99	31-47 (4 speed)
42083	11mm 1-1/2"	92	31-47 (5 speed)
3220	11mm 1-1/2"	96	29-44, 28-44



## 13.8mm Polychain Primary Belts

PCP	Size	Teeth	F/R Pulley
42081	13.8mm 1-1/8"	78	Sturgis (stock)
3213	13.8mm 1-1/2"	78	Karata
42084	13.8mm 1-3/4"	78	Karata

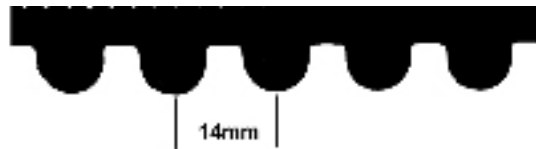

## 14mm Primary Belts

PCP	Size	Teeth	F/R Pulley
3214	14mm 1-1/2"	69	Polychain
42082	14mm 1-3/4"	69	As above
3216	14mm 1-1/2"	78	24-37, 24-38 (4 speed)
3217	14mm 1-1/2"	72	24-37 (5-spd) BT 80-84



## Rear Belt 'T' Nuts

12628 5 Pack (7669)



## Transmission Shaft Nut with Seal

Nut with seal for all BDL and Primo kits.

76213

**41mm = 1-1/2"**

**42mm = 1-5/8"**

HTD® and Poly Chain® are registered trademarks of the Gates Rubber Company

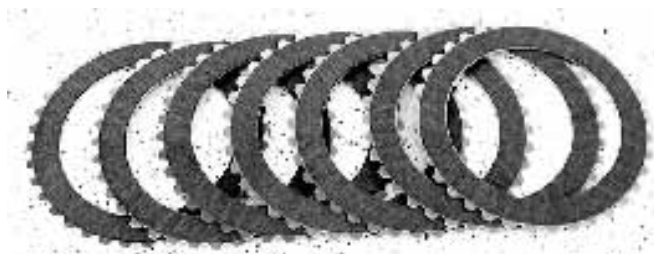

### Kevlar Clutch Pack for Chain Drive

Set of 7 plates which can also be used with BDL competitor clutches.

**76454**

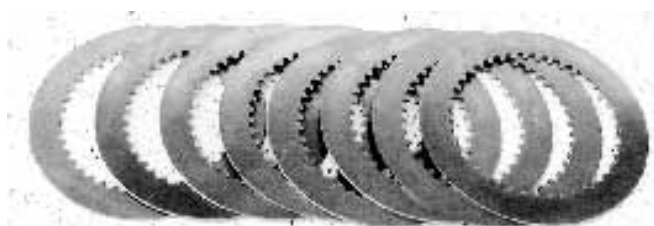

### Steel Drive Plates for Chain Drive

Set of 8 drive plates.

**76455**

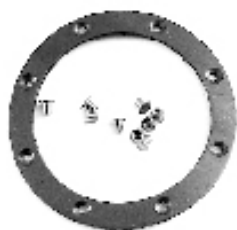

### BDL Clutch Hub Disk Kit

Teflon disk kit includes rivets for BT 1936-84.

**76436**



### BDL Big Fix Bearing Kit

Fits BT 1941-84.

**76438 BF-1**

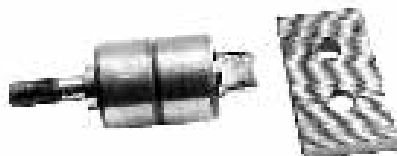

### BDL Idler Bearing Kit

**76437 IBK-1**



### BDL Primary Chain Drives with Competitor Clutch

Kevlar clutch provides 60% more clutch surface than stock and the 9 spring pressure plate provides all the spring pressure needed for stock to strokers. Competitor clutch provides transfer of power to the rear wheel. Kits include front sprocket, rear basket with Competitor Clutch, primary chain and adjuster assembly.

#### PCP Description

**76302** 1970-84 Electric start

**76424** Replacement ring gear

**76305** Kickstart basket only 1936-83

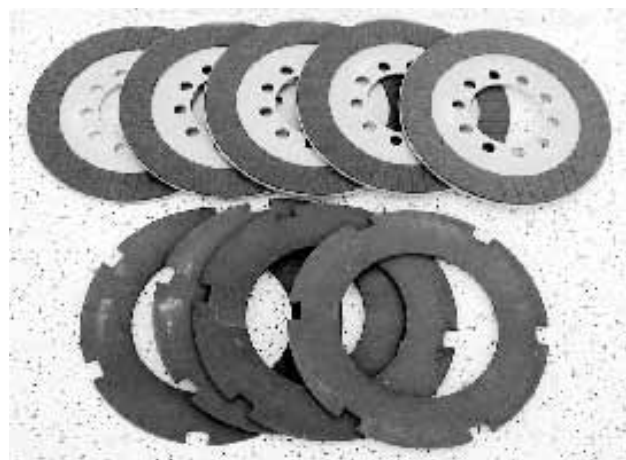

### BDL Big Twin 1941-84

Clutch kit includes 5 Kevlar frictions and 4 steel plates.

**76460**



### Belt Guides

#### PCP Description

**76439** Inside belt guide

**76440** Outside belt guide

**76441** Flat hex nut spline size

**76442** Washer spline size

# BDL



## BDL "Competitor Clutch"

For all Shovelhead chain and belt drives 1936-84. Features 9 springs and shoulder bolts for easy spring adjustment. A large 40mm double row hub bearing provides maximum performance and strength. The polished pressure plate adds a custom touch for open belt drive installations. Also includes a race proven Kevlar clutch.

**76420**

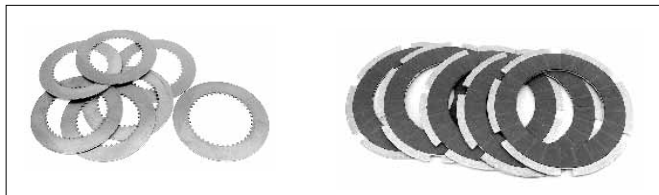

## Replacement Clutch Fibers and Steels

PCP	Description
76447	Set of 5 fibers for #76420
76448	Set of 7 steels for #76420



## BDL 25 Tooth Chain Compensator

**76475**

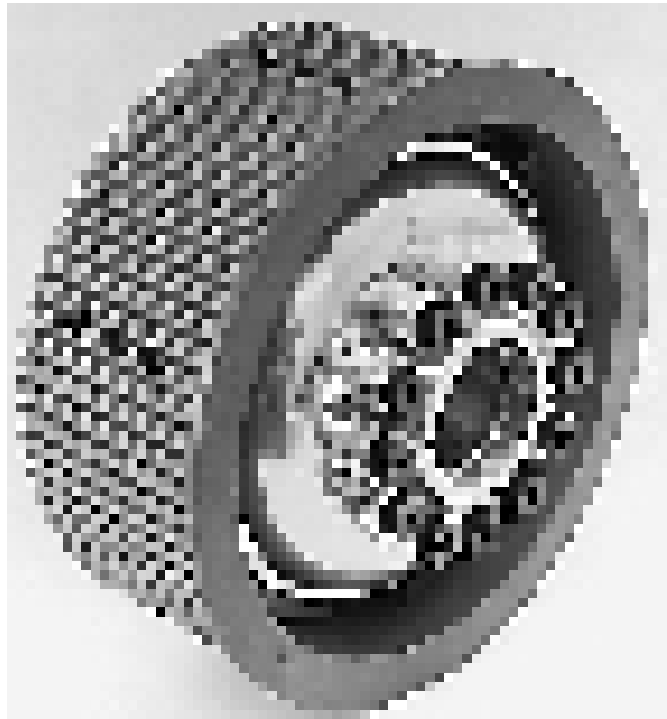

## BDL Retro Fit Clutch for 3" 4 Speed Drives

Clutch design moves the weight in-board over the bearing to eliminate the gyro effect of the stock or early style hub. Fits all 3" belt drives 1936-E84. To be used with existing 3" front pulley and belt. Competitor Clutch package includes: clutch basket, 40mm double row sealed bearing, 6 Kevlar clutch plates, steel hub, 5 steels, hardware and a 12 hole polished pressure plate with springs and shoulder bolts.

**76422**

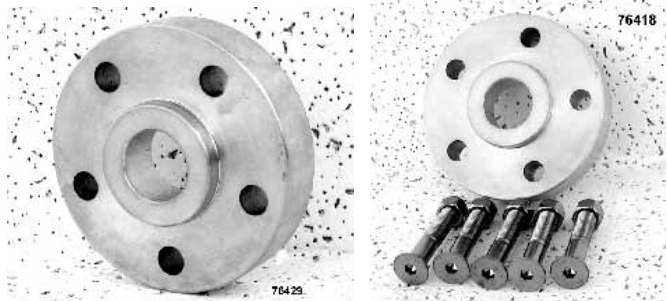

## BT Rear Wheel Spacers (BDL)

PCP	Size	BDL
76427	.250"	RPS-0250
76428	.375"	RPS-0375
76429	.500"	RPS-0500
76430	.750"	RPS-0750
76431	.937"	RPS-0937 for use with BDL 1" pulley
76418	15/16"	RPS-100
76432	1.100"	RPS-1100 for use with CCI wheels
76433	1.250"	RPS-1250

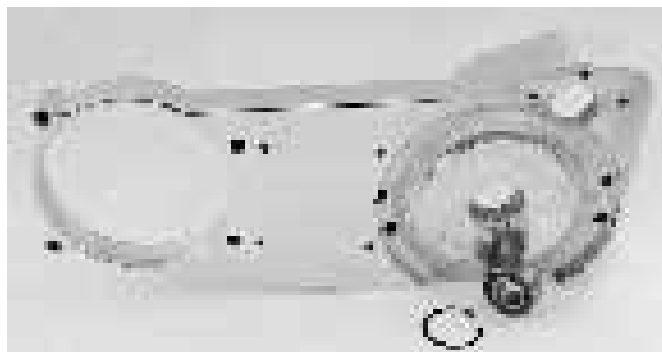
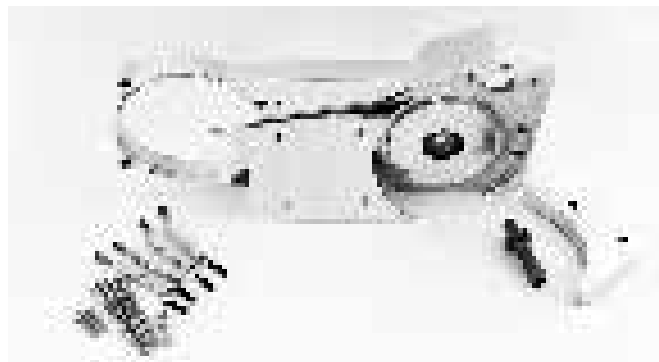

**BDL 3" Electric Start Complete Motor Plate Kit**  
76345 Shovelhead (BDL-1000P)



**Primary Spacers**

PCP	Size
76456	1/4" spacer
76457	1/2" spacer
76458	3/4" spacer
76459	1" spacer

**BDL Starter Pinion Gear**

Replacement parts for 3" electric start.  
76212 All Shovelhead (2.750 O.A.L.)

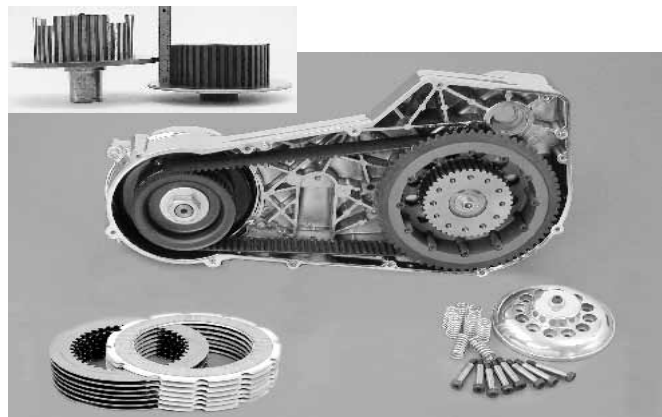

**8mm x 42mm (1-5/8") Electric Start Belt Drives**

Innovative design features for bolt-in application which allows the belt to track on the correct geometry plane while reducing the need for extensive grinding of the inner primary. The clutch basket features 12 cylindrical replaceable clutch dogs which allow drive plate to make constant contact for quieter operation. Polished pressure plate uses 6 shoulder bolts and springs for easy installation. "Competitor Clutch" has Kevlar clutch plates for maximum performance. Also included is a sealed bearing for the inner primary and a seal for those who do not want to replace the stock bearing. These units are for rear belt drive models only. Only 1 kevlar belt included.

**For Shovelhead 1-1/2"**

- 76316 68-45T With rear chain 4 speed 1965-83 (41mm)
- 42064 Replacement belt for above unit
- 76317 68-45T With rear belt drive 4 speed 1979-84 (42mm)
- 42062 Replacement belt for above unit



**Pulley Inserts For Replaceable Style (Primo)**

PCP	Description
76468	1/4" insert and special nut with screws
76469	1/2" insert and special nut with screws
76470	3/4" insert and special nut with screws
76471	1" insert and special nut with screws
76472	1-1/4" insert and special nut with screws

**BDL Ring Gear**

76423 1965-83

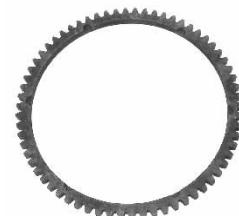

# BDL



## BDL 8mm 3" Electric Start Shovel Belt Drive

Kit includes 1.2 kw black wrinkle starter and fits Shovelhead 1970-E79 with ratchet tranny lid. Mini dome covers with tape for bolt-less installation and button bolts for on/off installation can be ordered separately.

PCP	Description
76337	Belt drive kit
3209	Belt for above kit
76443	Mini dome covers for above kit

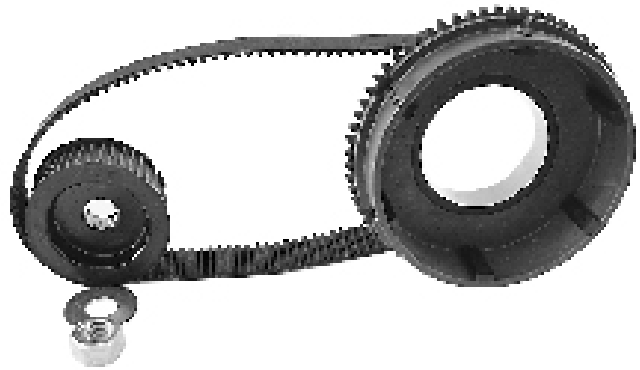

## BDL 1-1/2" 8mm Belt Drives Pan-Shovel

These units are a great choice for all around riding and dependability. BDL competitor clutch can be used with these drives for superior performance over stock Shovelhead hubs and clutches.

PCP	Description	Year	Belt
76318	61-41 8mm electric start	1965-78	3204
76319	61-41 8mm electric start	1979-84	3206
76320	61-41 8mm electric start with rear belt drive	1979-84	3206
76321	62-39 8mm kick start taper shaft	1936-54	3206
76322	62-39 8mm kick start spline shaft	1955-64	3206
76323	62-40 8mm kick start spline shaft	1965-78	3206
76324	61-41 8mm kick start spline shaft	1979-84	3206



## BDL 8mm 2" & 3" Belt Drives- 4 Spd Kickstart

2" and 3" drives are made from 356T6 aluminum. Each drive includes a big fix kit and requires safety guard at all times.

PCP	For Kickstart Models	Year	Belt
76341	76-47 2" Spline engine shaft	1955-84	3208
76342	76-47 3" Taper engine shaft	1936-54	3209
76343	76-47 3" Spline engine shaft	1955-84	3209



## BDL 1-1/2" 11mm Belt Drives for BT 4 Speeds

Large pitch tooth profile can be used with BDL competitor clutches.

PCP	Description	Year	Belt
76325	47-31 11mm kick start taper shaft	1936-54	3199
76326	47-31 11mm kick start spline shaft	1955-64	3199
76327	47-31 11mm kick start spline shaft with idler	1965-84	3199
76328	47-31 11mm electric start with idler	1965-84	3199
76329	47-31 11mm electric start with idler *For models with rear belt drives with rear belt model inner primary	1979-84	3199



## BDL 3" Replacement Basket

Includes basket, gear, dogs and bearings.

76298 Shovelhead



### Laser Etched 3" Front Pulley

Front pulley for 3" belt drive has laser etched numerals from 0-360 degree. The perimeter numbering allows for convenient and accurate timing of the motor without removing the timing hole plug.

**76039** 1955-84 8mm Splined shaft (P-47-S-3N)



### Primo 8MM 3" Open Belt Drive Units

Open belt drives for pre Evo Harleys with adjustable transmission only. A full 3" wide. Primo belt drive pulleys are hard anodized for durable, long lasting service. All rear pulleys have hardened clutch dogs, each secured with two stainless steel rivets. Primo races are made from a special chrome-moly carbon steel alloy.

**76106** 1937-54 taper shaft (P-47-76-E)

**3209** 8mm x 144T belt for above unit

.....  
 • **Note:** All belts by Primo, Karata or BDL are manufactured  
 • by Gates Rubber, Goodyear or Dayco Panther.  
 • Belts **do not** carry any warranty, of any kind, whether sold  
 • separately or in a complete kit.  
 .....

### Primo 8mm Front Pulleys 74 & 80 HD

PCP	Primo	Year	Type	Belt
<b>76030</b>	P-39-T	1937-54	Tapered shaft	1-1/2" Belt (use with adjustable transmissions)
<b>76031</b>	P-39-S	1955-64	Splined shaft	1-1/2" Belt (use with adjustable transmissions)
<b>76032</b>	P-40-S	1965-77	Splined shaft	1-1/2" Belt
<b>76033</b>	P-41-S	1965-84	Splined shaft	1-1/2" Belt
<b>76034</b>	P-47-T-2	1937-54	Tapered shaft	2" Belt (open installation)
<b>76035</b>	P-47-S-2	1955-84	Splined shaft	2" Belt (open installation)
<b>76037</b>	P-47-S-3	1955-84	Splined shaft	3" Belt (open installation)
<b>76039</b>	P-47-S-3N	1955-84	Splined shaft	3" Belt (open installation)

### Primo 11mm Front Pulleys 74 & 80 HD

<b>76040</b>	P-31-T	1937-54	Tapered shaft	1-1/2" Belt (for use with 47 tooth rear pulley)
<b>76041</b>	P-31-S	1955-84	Splined shaft	1-1/2" Belt (for use with 47 tooth rear pulley)

### Primo 8mm Rear Pulleys 74 & 80 HD

<b>76042</b>	P-62-K	1937-64	Rear pulley	1-1/2" Belt (kick-start only, closed primary)
<b>76043</b>	P-61-K	1965-84	Rear pulley	1-1/2" Belt (kick-start only, closed primary)
<b>76044</b>	P-61-E	1965-84	Rear pulley	1-1/2" Belt (electric-start, closed primary, 4-speed)

**BDL 11mm 1.5" Electric Start Rear Clutch Drum Replacement**  
**76492** (47E)



# Belt Drive Accessories



## Polished Pressure Plate

Precision machined alloy pressure plate for BT 4 speed 1941-84 with a steel centre insert for clutch adjusting screw.

1532

## Polished Clutch Dome for Big Twin 4 Speeds

These clutch domes give that finished custom look to our open belt drive units. It also helps protect your leg from spinning parts. Fits BT to 1984 (except diaphragm clutch).

42100 3 Hole

42102 5 Hole

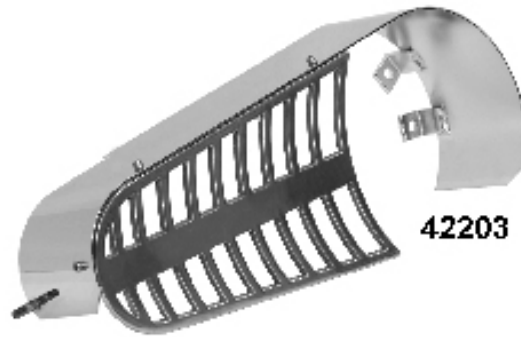

## Safety Belt Shrouds for Open Belt Drives

Recommended for all open installations, a necessary safety item. Manufactured from steel and chrome plated, complete with a welded-on mounting tab for easy installation.

**Alternator style requires PC #700 or #42103 (chromed) for mounting.**

42200 Fits 1937-69 (generator) with 1-1/2" or 1-3/4"

42203 Fits 1970-E84 4-speed alternator models (except diaphragm clutch) with 1-1/2", 2" or 3" belt system



## Bearing Support

For use when cast aluminum inner primary is removed for installation of open belt drive on BT 4-speeds 1966-84 because the mainshaft requires additional support.

42106 Chain type (no bearing) fits with belt front & rear c/drive

15718 Bearing only unshielded 1970-E84



## Alternator Cover BT 1970-84

Designed to protect your alternator, also helps cool by acting as a heat sink. It has a mounting lug for our belt shroud built in. Highly recommended for all open belt drive installations.

700 Polished

42105 Chromed

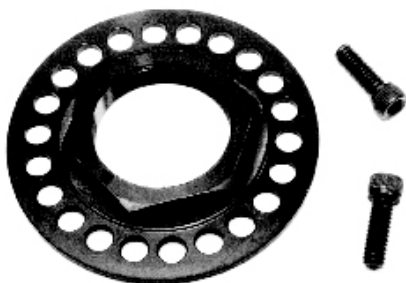

## Pulley Indexing 'Mega' Nut

Nut allows drilling and tapping for additional set screw locations.

12629



## Primo Starter Ring Gears

Designed as a replacement for OEM gears on BT models.

**PCP Application**

76024 Early Primo belt drive baskets (3 hole) (PP-118)

76025 Pre-Evo electric start Primo pulley (6 allen bolts) (PP-118-L-66)

76026 Sturgis (PP-118-S)

## Chrome Acorn Sprocket Nut

5100 Big Twins 1936-54.

1815 Big Twins 1955-76.





# Belt Drive Pulleys



## 14mm (1 1/2") Rear Wheel Belt Pulley

Stock black bolts to standard rear 5 bolt pattern. Stock ratio 2.121 on 4 speeds, 2.187 on 5 speeds.

**PCP Model**

**65502** 70T BT 5 & 4 spd, 1980-on FXSB (40217-79A)



## BDL 4 Spd Pulley BT 1979-84

PCP	BDL	Description
76401	TPSH-29	29T
76402	TPSH-30	30T
76403	TPSH-31	31T
76404	TPSH-32	32T (stock)
76405	TPSH-33	33T

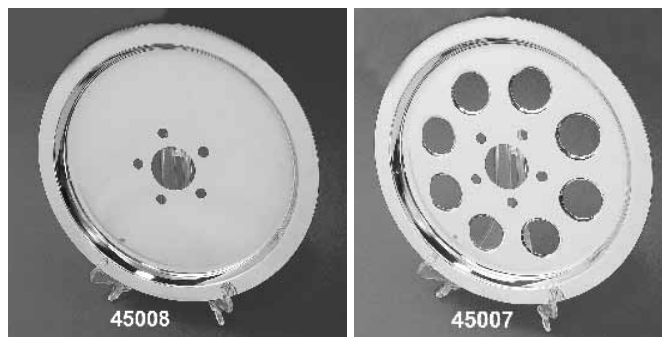

## Chrome Belt Drive Sprocket Insert Kits

Top-quality chrome-plating on formed 'deep dish' steel rear wheel belt pulley inserts. Sprocket insert kit includes a set of chromed button head Torx fasteners and 3/8" drive Torx bit.

**PCP Description**

**45008** Complete outer cover with hardware 8 holes 1980-on w/70T (12 3/4"OD) (91733-85A)

**45007** Insert only (12 3/4" OD) for 70T as above (91740-87A)

**45802** Inner cover, 70T 1980-97 to fit above

## Solid Inserts

**45005** Insert only (12 3/4") for all 1980-on w/70T pulley (91740-87A)

**45006** Complete with hardware (12 3/4")



## Button Head Screws

5 piece set for rear belt pulleys on 1981-on FXSB. Replaces 3771. Includes TORX socket.

**24020** Kit

**24021** Screws and washers only



## BT Chrome Rear Drive Pulley

Pulley fits 1.5" belt on Big Twin models 1980-99.

**37229** 70T

# Outer Primary

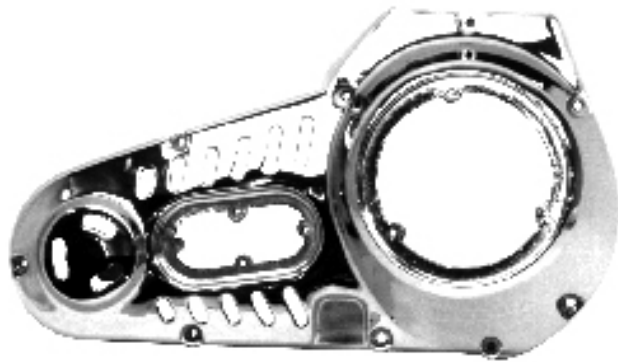

## Vented Primary for FXE 1970-E84

This vented cover provides additional cooling and a custom look for a 4 speed Big Twin FXE 1970-E84 running a primary belt drive.

**86000**

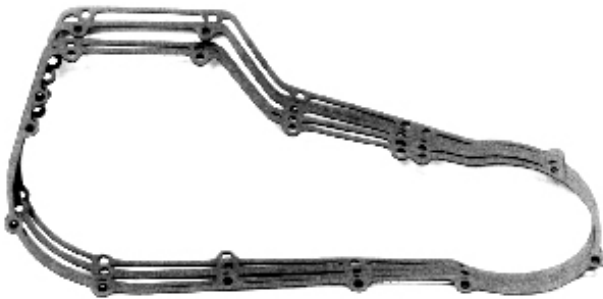

## Primary Cover Gaskets for Big Twins

Replacement primary cover gaskets for Big Twins 1965-up, James Products where noted.

### PCP Application

- 79423** James 65-80 FL,FX .032 8 hole (60540-65) (10)
- 79427** As above .062 w/bead 8 hole (60540-65-A) (5 pk)
- 150400** Gary Bang, as above .032 w/silicone 8 hole (5 pk)
- 79416** James .062 as above 9 hole (60538-81-A) (5 pk)
- 79328** James 1979-L83 FLT, FXR .030 (34901-79A) (10 pk)
- 79329** James 1979-L83 FLT, FXR .062 (34901-79A) (5 pk)
- 79330** As above with silicone (34901-79B) (5 pk)
- 25153** 1965-85 FL/FX .062 w/bead (60538-81A) (5 pk)
- 79417** James as above (5 pk) w/silicone (60531-81-C)
- 150401** Gary Bang 1965-85 .062 9 hole

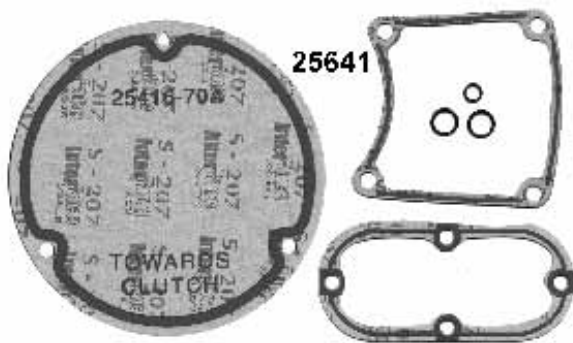

## Primary Derby Gasket Kit

Perfect for use after clutch and primary chain adjustment on BT models 1970-on. Includes gaskets and seals.

### PCP Application

- 25641** 1970-98 3 Hole



**2435**

## Aluminum Primary Floorboard Mounting Kit

Fits BT 1965-84 FLH-FXE models equipped with FL type forward controls and primary cover with floorboard tab.

### PCP Application

- 2435** Complete kit 1966-82
- 5787** Kit for models with custom pipes
- 10874** Right front short stud FL 1970-E79 (50657-70A)
- 4700** Right rear bracket 1970-84 (50655-70)
- 10837** Left front long stud 1970-84 (50658-70A)
- 10838** Right front stud 1970-84 (50659-70)

Note: PCP# 5787 includes extended rear floorboard bracket when using custom drag or muffler pipes

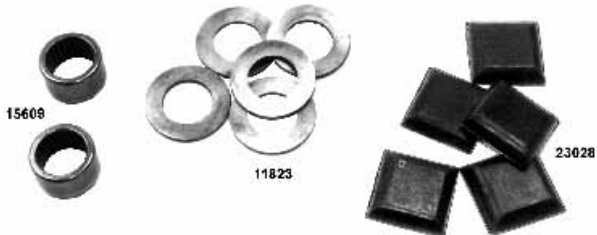

## Primary Hardware

### PCP Description

- 15609** Outer primary bearing 1965-88 (9063) (each)
- 11823** Starter shaft washer 1965-88 (31502-65) (5 pack)
- 23028** Kickstand bumper pad (50100-70) (5 pack)

**25890**

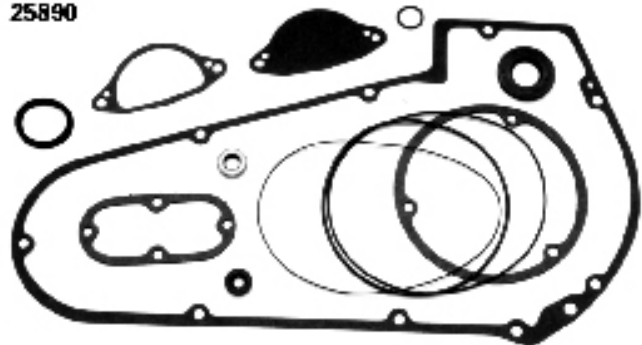

## Preston BT Primary Cover Repair Kit

This kit contains all the necessary parts that are required when making inner primary repairs, primary chain service, clutch hub service, or left side transmission repairs.

- 25890** 1965-E82 4 speed
- 25891** L1982-84 4 speed
- 25892** 1980-84 FLT-FXR

# Outer Primary

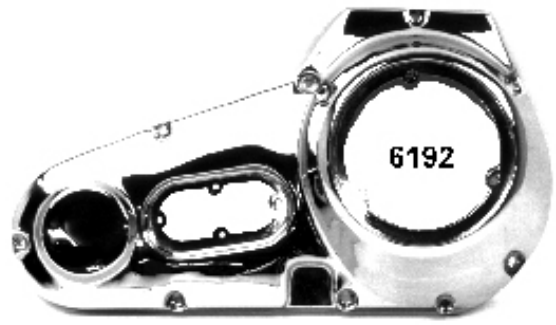

## FLH Primary Covers 1970-85 4 Speeds

- | PCP   | Description   |
|-------|---|
| 6190  | Chromed less hardware, 9 hole (60508-70)                                  |
| 6191  | Polished less hardware (60508-70)   |
| 86034 | Chrome 1982-84 9 hole for FL front belt with factory rear belt (60525-82) |



## FXE Primary Covers 1970-85 4 Speeds

Add both beauty and strength to your motorcycle with the stronger-than-stock construction found in this reinforced die-cast outer primary cover. Has partially tapped ninth hole for nine hole applications. For 4 speeds.

- | PCP   | Description  |
|-------|--|
| 6192  | Chromed FXE less hardware 1970-82 (60507-77)   |
| 6193  | Polished FXE less hardware 1970-81   |
| 86037 | Chromed 1982-85 FXSB (front belt) with factory rear belt, includes screws, bearing, inspection & derby gaskets (60531-83B) |
| 86009 | Chromed FX models 9 hole 1983-85 less hardware .350" from gasket hole to bearing surface (small locate hole) (60531-83B)   |



## Chrome Primary Cover Screw Kits

- | Acorn | Cap  | Allen | Description                      |
|-------|------|-------|----------------------------------|
| 1756  | 5245 | 5348  | BT 1936-64 (stamped steel)       |
| 1721  | -    | -     | BT 1965-70 (cast aluminum cover) |
| 1742  | -    | 5354  | BT 1971-on 4-speed               |
| 1735  | 5753 | -     | BT 1965-79 (pressed metal cover) |
| 5247  | 5248 | 5355  | BT 1980-84 5-speed               |

## FLT & FXR Primary Covers 5 Speeds 1980-84

Used on all 1980-88 FLT, Classic and 1982-88 FXR's. Cast construction to OEM specifications, supplied with no hardware.

- |      |                                      |
|------|--------------------------------------|
| 6194 | FLT 1980-84, FXR 1982-84 (60605-79B) |
|------|--------------------------------------|

## Stainless Steel Allen Bolts

- |       |                    |
|-------|--------------------|
| 24037 | BT Primary 1970-84 |
|-------|--------------------|



## Chain Housing Needle Bearing

Use for starter drive. Replaces #9063 on 1965-88, 74", 1967-on XLH.

- |       |
|-------|
| 15609 |
|-------|

# Inspection & Derby Covers

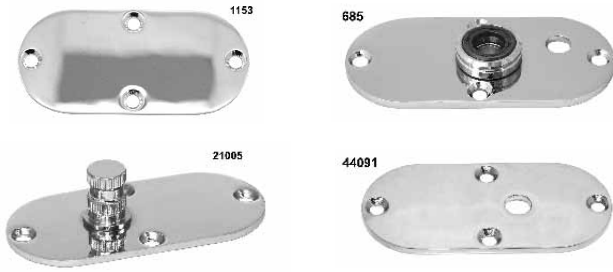

## Chrome Inspection Covers

Flat steel covers for Big Twins with forward controls.

**PCP Fits**

**1153** 4 speed FL models 1965-1984 and FXWG models 1980-1985 (countersunk holes) (60572-78T)

Flat steel inspection covers for Big Twins with through-the-primary shift and/or foot peg mount.

**PCP Fits**

**685** 4 speed FX models 1974-1985 with through-the-primary shifter and foot peg mount (60579-74T)

**21005** FL 1965-1977 with splined mount (60574-65)

**44091** 1971-73 FX with foot peg hole (60513-71)



## “Eagle Spirit” Inspection Covers

Fits 4-speed FL models 1965-1984, FXWG 1980-on and most FX 4 speeds with forward controls.

**5059** Chrome



## Chrome Inspection Covers for 5 Speeds

Without Shift Holes

**PCP Application**

**44504** FLT, FXR 1982-86 (forward control) (32519-80)

With Shift Holes

**44503** FXR 1982-84 (60642-82)

**18592** Early bushing 1982-E84 (60629-82) (each)



## Chrome Billet Oval Inspection Cover

**44089** Fits 1965-on Big Twin



## FX Inspection Cover Bushing and Seal 1974-85

**PCP Fits**

**14070** Seal (60641-74) (not FXWG) (5 pk)

**18591** Bushing (60593-74) (each)

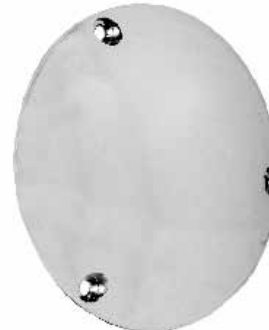

## Diecast Derby Covers BT 1970-98

**PCP Description**

**1368** Chrome smooth cover (60668-84-B)

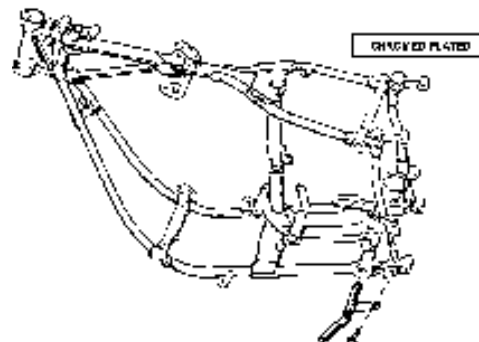

## Case Saver BT 1958-84

A simple economical answer to saving those primary cases when you lay the bike over. Simple bolt on installation—Solid bar stock—Highly chrome plated. Installation bolt not included.

**6588** Case saver

# Inspection & Derby Covers



## Flame Covers

Chrome plated diecast designs for BT 1970-on

### PCP Description

- 45164** Derby cover
- 45165** Points Cover (holes F/T/B)

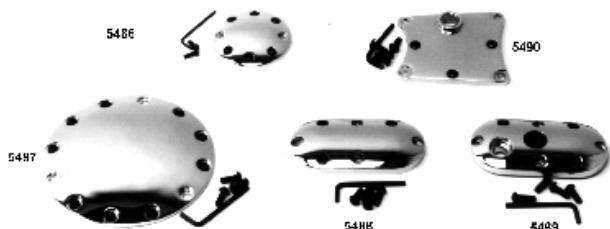

## Finned Primary Cover Accessories

An assortment of accessories for 4-speed Big Twin primary covers as well as all Big Twin point covers. Available in chrome or with a durable black powder coat finish.

### Chrome Black Fits

- 1369** **3753** Derby cover 1970-98
- 3292** **3754** Inspection with shift bushing 1974-85
- 44088** Inspection cover 1965-on
- 3102** Point cover (verticle screw placement)

## Domed Derby Covers and Inspection Plates

Chrome plated covers with extra non-functional buttonhead Allen screws for that high-tech look.

### PCP Fits

- 5486** Domed points cover
- 5487** Derby cover (25414-70) 1970-98
- 5488** Inspection cover (60572-78)
- 5489** Inspection cover FX 1974-on w/mid-shift (60579-74)
- 5490** Inspection cover FXR models 1982-84 except diaphragm clutch (60642-82)



## Billet Slotted Chrome Oval and Derby Kit

Fits 1970-98 primary covers.  
**59265**

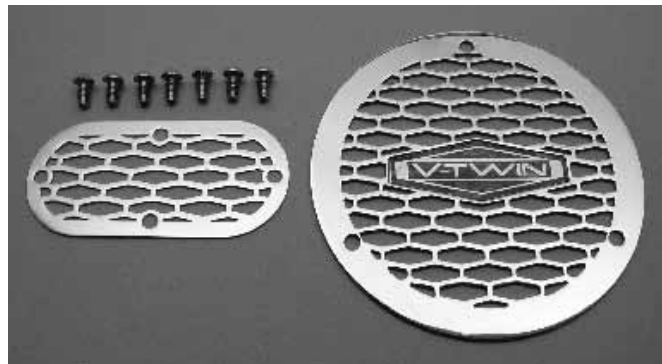

## Chrome Vented Oval and Derby 1970-99

Fits 1970-99 4 speed models, features V-Twin design venting for belt drive applications.

- 45552** Oval and derby kit
- 86001** Derby

# Inspection & Derby Covers



## Chrome Skull Design Cover

PCP	Type	Application
45482	Points	1970-98 BT
45483	Points	1971-on XL
59171	Derby	1970-98 BT



## Chrome Maltese Cross Covers

PCP	Cover	Type
59184	Derby	3 Hole BT
59186	Points	2 Hole

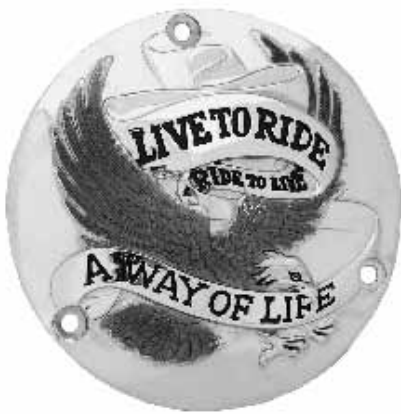

## “Live To Ride” Chrome Derby Covers

Die-cast aluminum construction with “Live to Ride” emblem. Fits BT 1970-98 models. Replaces OEM 25391-84T.

6592	Chrome
45210	Gold

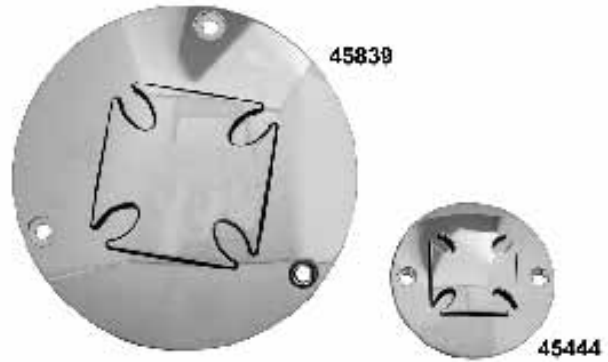

## Billet Iron Cross Derby and Point Covers

Features chrome Billet cover with chrome raised iron cross.

45839	3 Hole derby
45444	1970-99 Big Twins points cover



## 3-D Derby

Features concealed mounting by use of plate which installs like a Derby. Chrome 3-D spinner cover mounts to stud on plate and is held firmly in place by O-ring. Backing plate may be painted to match colour scheme.

59002

# Gaskets

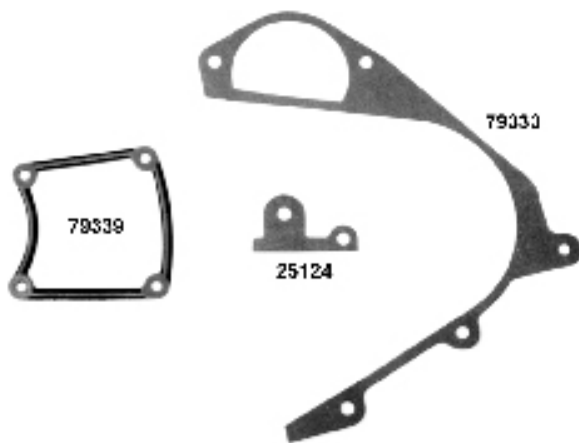

## James Gaskets FLT-FXR

### PCP Application

- 25124\*\*** 1979-85 .030 inner chain (34903-79) (10 pk)
- 79333** 1979-85 inner chain .035 (34902-79-A) (10 pk)
- 79337** 1979-84 inspection .030 34906-79) (10 pk)
- 79338** 1979-84 w/silicone-2 sides .062 (34906-79-A) (5 pk)
- 25127\*\*** As above no silicone, JAN'S (10 pk)

\*\*Note: Not James

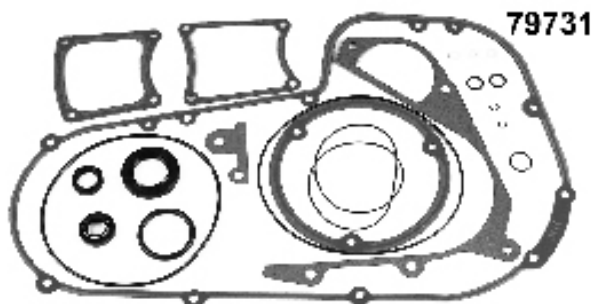

## James Primary Gasket Kit

Fits FLT, FXR 1979-83 .062 primary.

- 79731** 34901-79-K

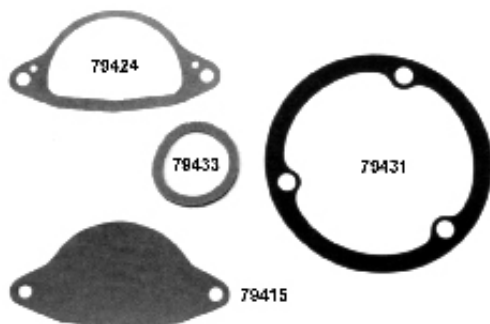

## James Gaskets

### PCP Application

- 79424** Starter motor to primary FL, FXWG 1980-85 (60559-80) (10 pk)
- 79415** Starter cover FL, FX 1965-on(60518-65) (10 pk)
- 79433** Solenoid gasket FL 1965-80 (60645-65) (10 pk)
- 79431** Primary to engine BT 1955-64 (60629-55) (10 pk)



## James Derby Cover Gasket

### PCP Application

- 79291** FLT, FL, FXR, FX 1970-83 .030 (25416-70) (10 pk)
- 79293** As above, w/silicone .062 (25416-70-X) (10 pk)

## Inspection Cover Gasket

- 79428** FL-FX 1965-on w/silicone 2 sides .062 (60567-65B) (5 pk)

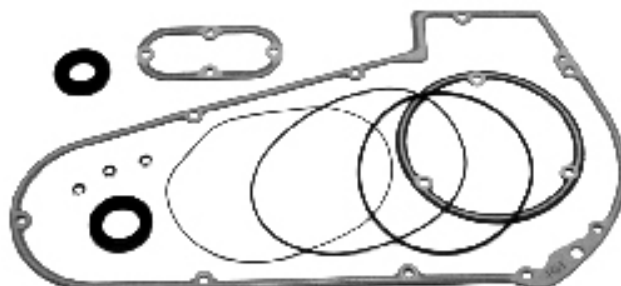

## James Primary Gasket/Seal Kit

Fits 1965-86 FL and FX.

- 79723** 60538-85-K

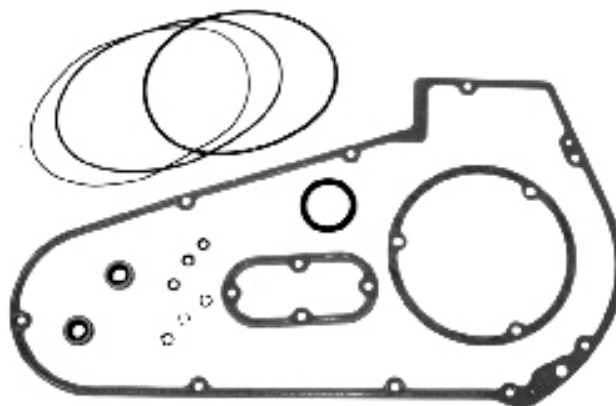

## James Primary Kit

Fits 1966-86 FL w/silicone.

- 79722** 60538-81-K

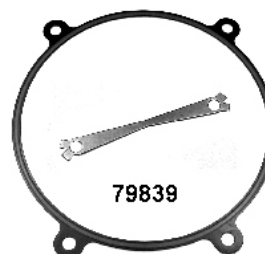

## Crankcase Saver Kit BT 1970-on

### PCP Description

- 79839** Metal gasket and lock plate only

# Inner Primary



## Revolution Cast Inner Primary Covers

Stock finish.

**PCP Application**  
**67613** 1980-84 FXSB (60502-80A)



## Chrome Inner Primary Trim Covers

Easily adapt to stock cast inner primary without complicated disassembly.

**3167** 1970-84 FX, FL

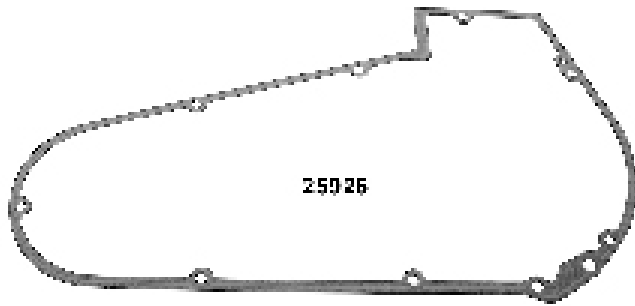

## Topline FL-FX Primary Gaskets - USA

**25926** 4 Speed primary 1981-85 (60538-81E) (5 pk)



## BT Inner Bearing and Seal Kit

**PCP Application**  
**15740** 4 Speed 1965-69 (9037)  
**15741** 4 Speed 1970-E84 (9061)  
**15742** 4 Speed 1970-E80 w/out seal, thin (9040)  
**14013** Seal 1970-84 (5 pack) (12018)

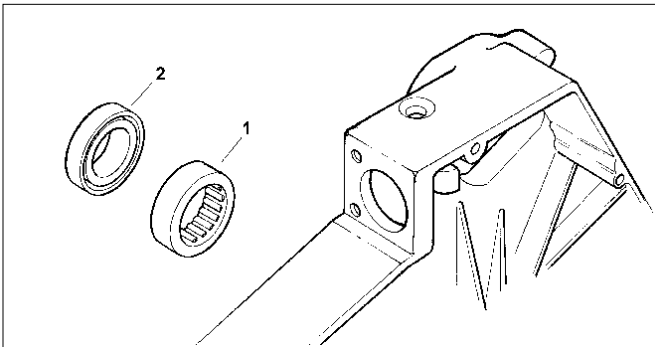

## BT 5 Speed Inner Bearing

**15705** FXR-FLT 1980-06, 2 shield (8975) (each)



## Inner Primary Mounting Bolts

**24158** BT 1970-86 (4021) (10 pack)



## Inner Primary Mounting Studs BT 1980-84

**877** 2-5/16" (16830-54) (4 pack)



# Inner Primary



## BT Block-Off Kit 4 Speed 1965-on

Zinc solenoid and starter hole cover kit FL-FX 1965-84.  
**3756** Kit (60646-65)

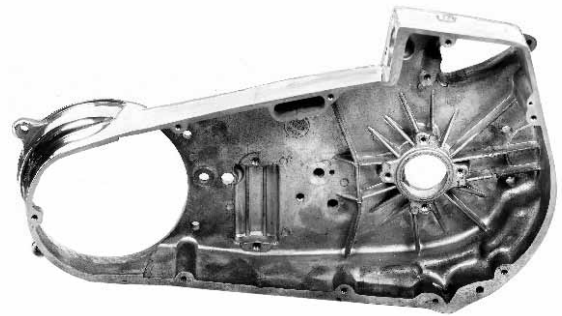

## 1970-85 FX and 1970-84 FL Complete Inner Primary Housing Assemblies

For 4 Speed models. Includes die cast inner cover in chrome or polished finish, bearing, seal, chain tensioner, detent plate, vent tube, chain oiler tube, and drain plug. Assembled.

- 86035** 1970-85 FX Polish
- 86042** 1970-85 FX Chrome
- 86036** 1970-84 FLH Polish
- 86043** 1970-84 FLH Chrome

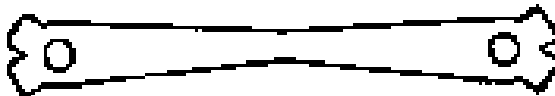

## Inner Primary Lock Tab

One piece design eliminates the need for safety wire on Big Twins 1970-on  
**13726** (5 pack)



## Case Saver

This reinforced nylon piece protects the inner case and starter housing area that can be damaged by the rear chain.  
**27143**

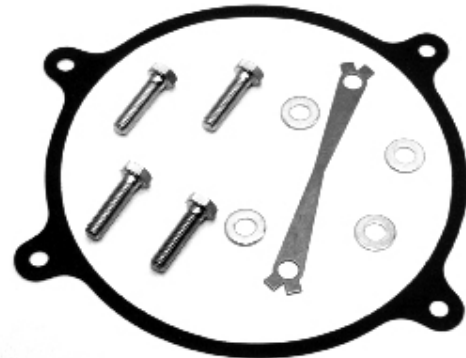

## O-Ring Replacement Gasket 1970-85 4 Speeds

This inner-primary O-ring replacement gasket replaces the O-ring when the lip of the motor is partially or entirely broken off. To avoid extensive machine work, welding, time and money, just grind the partially broken lip smooth for installation.

- 25157** Alternator gasket
- 79839** James, steel gasket w/bead and lock tab only



## Inner Primary Mounting Kit 1980-85

Complete hardware kit properly mounts inner primary on 1980-85 FL and FX models.  
**9869**

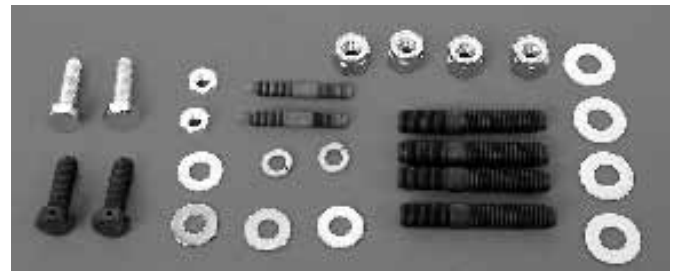

## Inner Primary Mounting Kit 1970-79

Complete hardware kit properly mounts inner primary on 1970-79 FL and FX models.  
**9868**

# 4 Speed Primary 1970-on

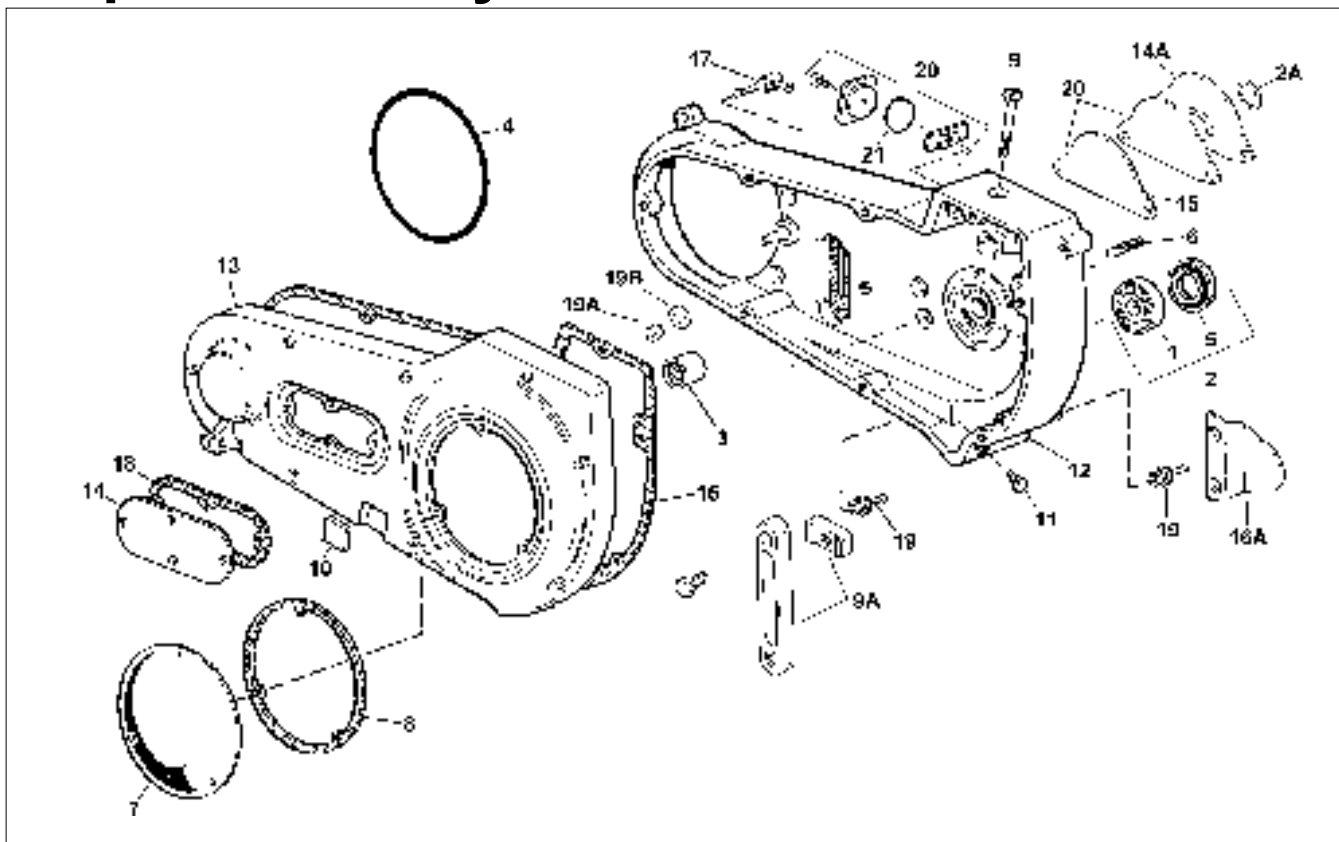

## Front Chain Housing FLH-FX 1970-on

#	PCP	OEM	Description				
1	15718	9040	Ball bearing unshielded	13	6192	60507-77	Chr. FXE primary cover 1970-82
2	15742		Ball bearing and seal kit 1970-E78		6193		As above, polished
2A	14501	11101	O-ring L1966-86 (10 pack)		6190	60508-70	Chrome primary cover 1970-85
3	15609	9063	Needle bearing 1965-88		6191		As above, polished
4	14515	11125	O-ring, inner cover 1970-82 (10)	14	685	60579-74	Chr. inspection cover FX 1974-85
	79022		As above, James (10 pk)		1153	60572-65	Inspection cover FL 1965-*
	14522	11147	O-ring, inner cover 1982-05 (10)	14A	4029	60516-65A	Deflector plate with o-ring
	79033		As above, James	15	79415	60518-65	Gasket, starter hole FX 1971-*
5	14013	12018	Oil seal 70-E84 (5 pk)	16	79423	60540-65	Gasket, housing cover James 1965-80 (10 pk)
	79062		As above, James (5 pk)		79427	60540-65A	As above, .062 w/bead (5 pk)
6	10828	24811-59A	Stud, start shaft housing 65-72 (5)		150400		As above, w/silicone (5 pk)
7	1368	25414-70	Chrome derby cover 70-98	16A	5493	60556-74	Primary baffle plate
8	79291	25416-70	Gasket, derby cover (10 pk)	17	3757	60549-70	Chain oiler fitting
	79293		As above with silicone (10 pk)	18	79428	60567-65	Gasket, inspection cover w/silicone 1965-* (5 pk)
9	4026	31478-65	Blk top screw, chain housing 65-*	19	10575	63533-41	Nipple, vent hose 1966-* (5 pk)
9A	3747	39992-65A	Chain adjuster slide bracket	19A	18591	60593-74	Shifter shaft bushing FX 1974-84
10	23028	50100-70	Bumper, jiffy stand (5 pk)	19B	14070	60641-74	Shifter shaft oil seal FX 74-84 (5)
11	10618	60348-65	Magnetic drain plug 1965-*	20	3756	60646-65	Cover kit, starter and solenoid hole BT 1965-on
12	86013	60411-79A	Front inner chain housing 70-84	21	79433	60645-65	Solenoid gasket (10 pk)

## Cast Inner Primary Covers

PCP	OEM	Year	Finish	Model
86013	60411-79A	1970-84	Polished	FL-FLH Chain
86008	60411-79A	1970-84	Chrome	FL-FLH Chain
86006	60441-82A	1970-85	Polished	FX-FXE Chain
86012	60421-79A	1970-85	Chrome	FX-FXE Chain

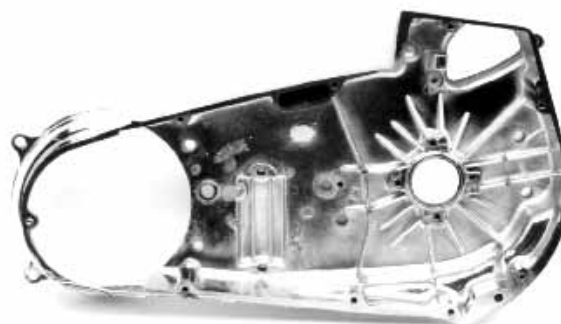

# FL 1965-69 Primary

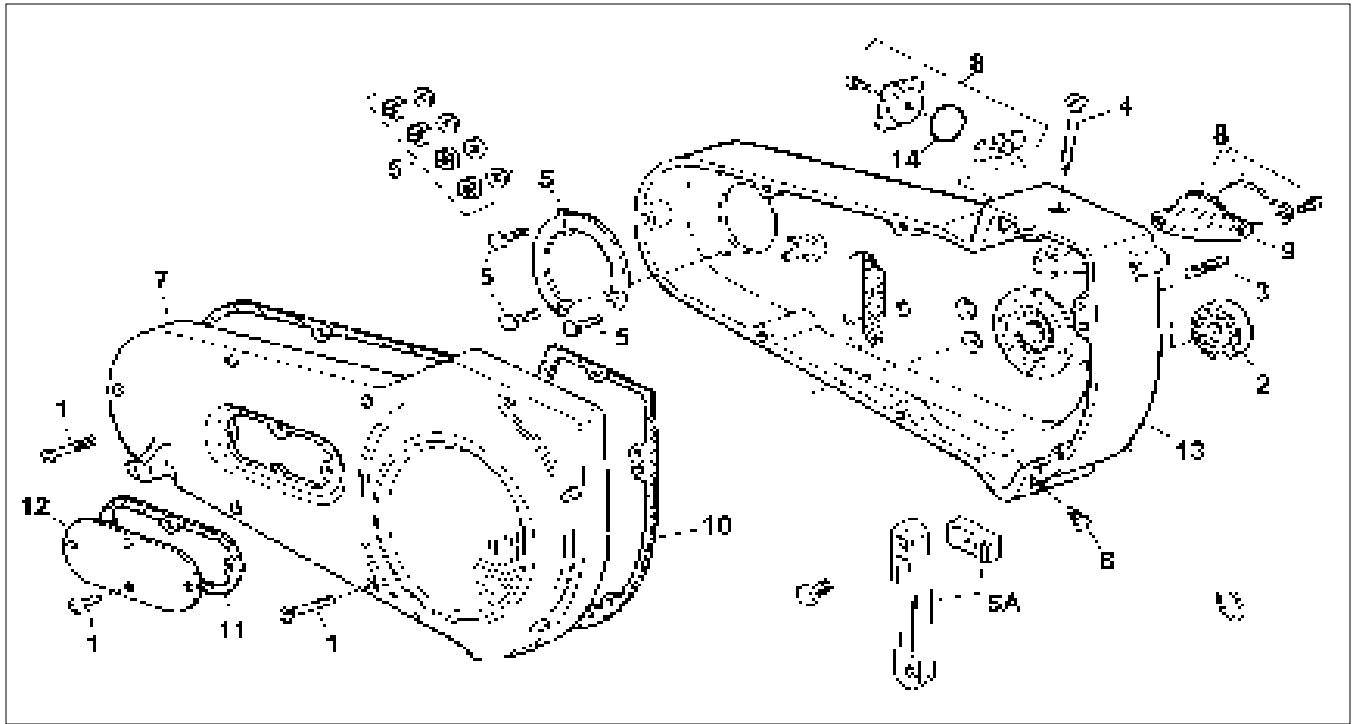

## FL Front Chain Housing 1965-69

#	PCP	OEM	Description	#	PCP	OEM	Description
1	1721	7146-12	Acorn screw kit, chrome (12 pc)	9	79415	60518-65	Gasket, starter hole cover
	5390	8799-12	Slotted screw kit, chrome (12 pc)	10	79423	60540-65	Gasket, primary .032 8 hole (James) (10 pk)
	5391	8800-12	Slotted screw kit, cad (12 pc)		79427	60540-65A	As above, .062 w/bead (5 pk)
2	15740	9037	Bearing and seal kit, inner housing		150400		As above, V-Twin 8 hole (5 pk)
3	10828	24811-59A	Stud, starter shaft housing (5 pk)	11	79428	60567-65B	Gasket, inspection cvr James (5 pk) w/silicone (5 pk)
4	4026	31478-65	Top screw, chain housing, black (ea)	12	1153	60572-65	Chrome inspection cover
5	5389	31479-65	Bolt and lock plate kit (12 pc)		21005	60574-65	As above, with spline mount
	10545	45830-48	Plug, chain housing vent hole 1965	13	86014	60617-65A	Inner housing, stock finish
5A	3747	39992-65A	Chain adjuster slide bracket	14	79433	60645-65	Solenoid gasket (10 pk)
6	10618	60348-65	Magnetic drain plug				
7	N/A	60508-65	Outer cover				
8	3756	60644-65	Cover kit, starter & solenoid hole 60646-65				

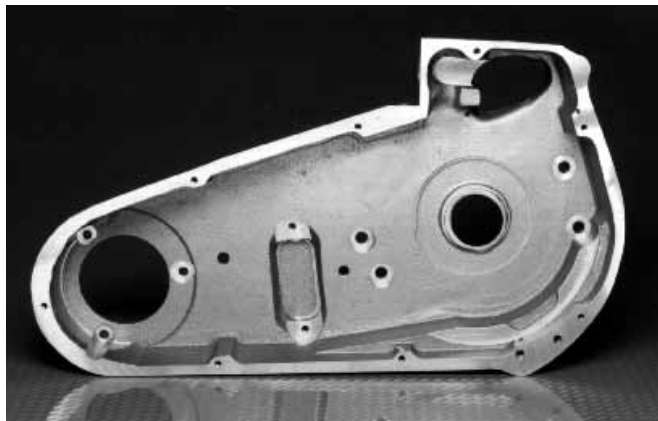

## Big Twin 1965-1969 Cast Inner Primaries

Replaces OEM 60617-65A. Available in a natural cast finish.  
86014



## Inner Primary Mounting Kit

Complete hardware & lock kit to properly mount cast aluminum inner primary cover to case on Harley Big Twins 1965-1969.  
5389



## Outer Primary Cover Kit 1965-69

Includes polished or chrome outer primary cover, chrome derby cover, chrome inspection cover, starter shaft extension, gaskets and screws.

86044 Polished  
86045 Chrome

# Primary Cover Accessories

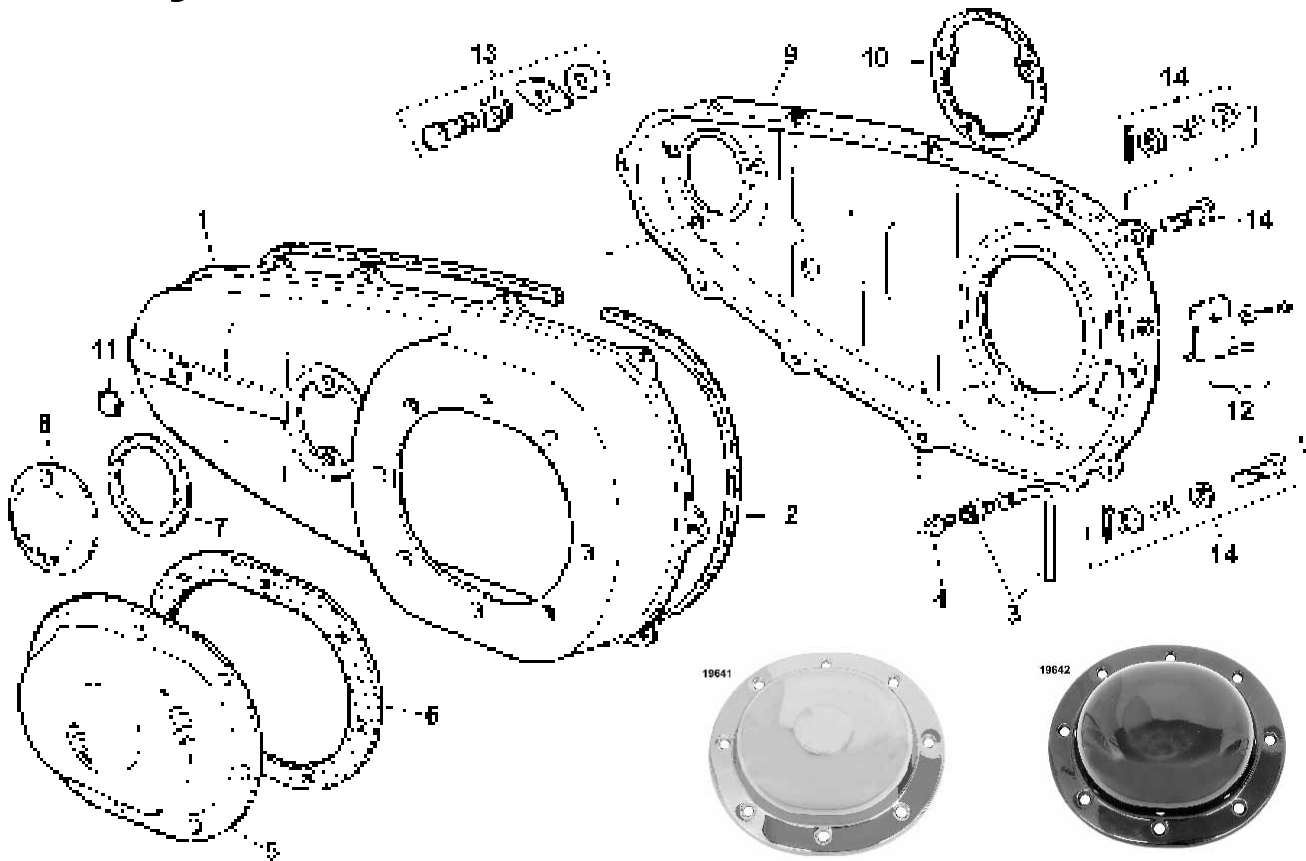

## Front Chain Housing 1936-64

#	PCP	OEM	Description
1	6475		Chrome outer "Diamond" housing 1936-54
	6476	60505-55	As above 1955-64
2	25155	60540-36	Gasket, housing cover (ea)
	79422		James as above (10 pk)
3	19376	60546-36	Cad drain pipe, & nut 1937-57
	19377	60546-59	Cad, as above, late 1958-64
4	19378	60548-36	Primary cover nipple for drain pipe
5	19641	60555-36	Clutch derby cover, chrome
	19642		As above, black
6	25158	60565-36	Gasket, clutch cover (10 pk)
	79425		James, as above (10 pk)
7	79426	60567-36	James inspection gasket (10 pk)
8	44077	60573-36	Inspection cover, chrome
9	6186		Chrome inner primary 1936-54
	6187		As above 1955-64
10	79431	60629-55	Gasket, chain housing back 1955-64 (10 pk)
11	73533	60650-54A	Plug, chain housing 1954-64 (5 pack)
12	19381	63591-62	Rear chain oiler kit 1954-64
13	1811		Inner primary mount kit 55-64 (12 pc)
14	9601		Parkerized case mount kit (10 pc)
	72071		Chrome, as above

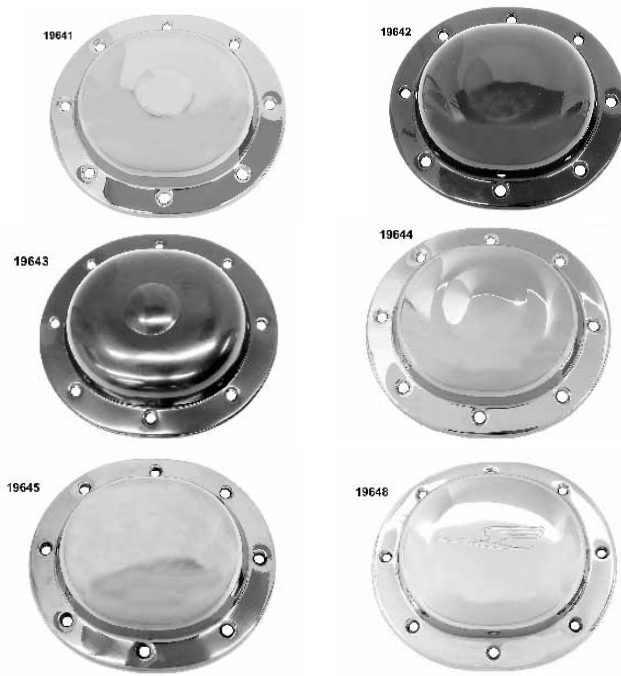

## Derby Covers for Tin Outer Primary 1936-64

Chrome unless otherwise stated.

PCP	OEM	Description
19641	60555-36	Derby with dimple
19642	60555-36	As above, black
19643	60555-36	Replica black with dimple
19644	60555-36	Replica chrome with dimple
19645		Replica SS with dimple
19648		Chrome bird Derby



## Inspection Covers

PCP	Description
44073	BT Flat (60572-36)
44075	BT Black
44076	BT Replica black
44077	BT Replica chrome
44078	BT Replica SS
44079	Flat XLCH 1952-70 models (60569-29)

# Tin Primary Covers



19831



- 6475** Chrome chain case cover 1936-54
- 19826** As above, black
- 6476** Chrome chain case cover 1955-64
- 19827** As above, black
- 19831** Chrome smooth 1955-64 compensator

## 1936-54 Big Twin Replica Outer Primary Cover

These primary covers are accurately shaped for proper fitment.

- 19863** Black
- 19864** Chrome

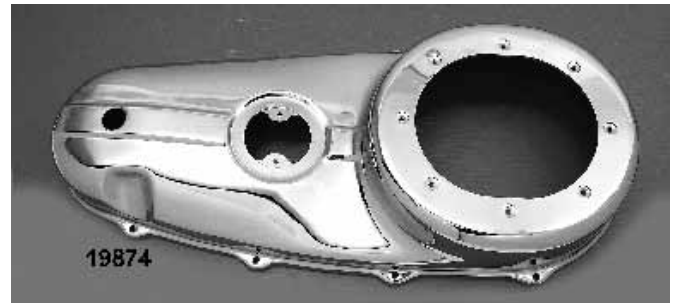

## Tin Primary Cover Screw Kits

- 1735** 74 1965-69 Stamped cover acorn
- 1756** 1936-64 Acorn

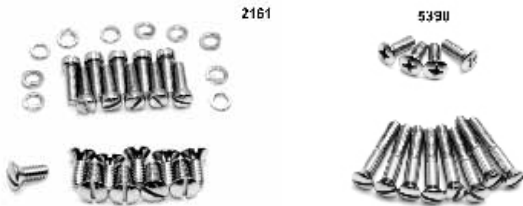

## Stock Primary Cover Screw Kits

Chr.	Cad	Application
<b>2161</b>	<b>5195</b>	BT 1936-64 (slotted)
<b>5390</b>	<b>5391</b>	BT 1965-69
<b>9307</b>	<b>9308</b>	Shovelhead 1970-80

## Outer Primary Cover for BT 1955-64

Order plug separately.

- | PCP          | Finish                      |
|--------------|-----------------------------|
| <b>19873</b> | Black                       |
| <b>19874</b> | Chrome                      |
| <b>73533</b> | Plugs                       |
| <b>25649</b> | Primary gasket and plug kit |

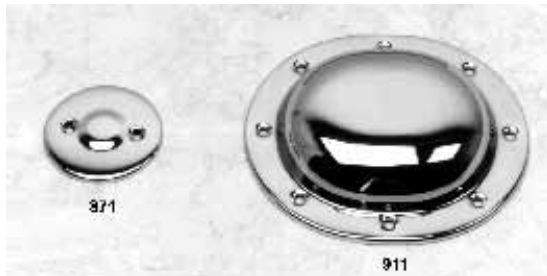
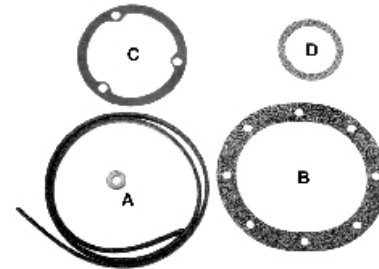

## Chrome Derby and Inspection Covers 1936-64

Finest plating and heavy-gauge material, fits all 74s with steel primary covers.

- 871** Inspection cover
- 911** Derby cover

## Primary Gaskets 1936-64

Fits 1936-64 U, UL, ULH, E, EL, FL, FLH.

James	Jans	Description
<b>79422</b>	<b>25155</b>	(A) Chain cover gasket (cork) (10 pk) (60540-36) (Jans sold each)
<b>79425</b>	<b>25158</b>	(B) Clutch cover gasket (cork) (10 pk) (60565-36) (Jans sold in a 10 pk)
<b>79431</b>		(C) Engine case to inner primary 1955-64 FL, FLH (60629-55) (10 pk)
<b>79726</b>		Kit including all pieces shown
<b>79426</b>		(D) Inspection (cork) (60567-36) (10 pk)

# Inner Primary

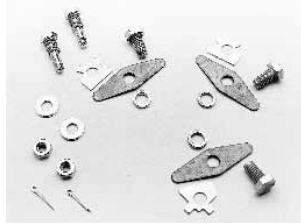

## Inner Primary Mounting Kit

This complete mounting kit contains reproductions of the original Harley hardware used to mount a stamped steel inner primary cover on Big Twins 1955-64.

1811

## Inner Primary Mounting Hardware Kits

Includes hardware required to mount a stamped steel inner primary cover to the engine. May also be used when converting a 65-69 FL to a stamped steel cover.

**PCP Fits**

1810 1937-54 Big Twin H-D #60554-36

## Inner Primary Reinforcement Ring

Use on all Big Twins 1936-54. Helps strengthen weak tin inner primaries.

5484



## Replica Inner Primary Covers

Features installed drain fitting.

**Black Chrome Application**

PCP	Chrome	Application
19848	19851	1936-54 (60626-36)
19859	-	1936-54 (60626-36)
19849	19852	1955-57 (60620-55)
19850	19853	1958-64 (60620-58B)

## Rear Chain Oiler BT

1955-64

Fits on rear of inner primary.

19381



## Rear Chain Oiler Kit 1954-64

Replaces 63591-62 on rear of inner primary cover. Includes screws.

**PCP Description**

19378	Rear chain oiler (60548-36)
19376	Oil drain 1937-57 (60546-36)
19377	Oil drain 1958-64 (60546-59)

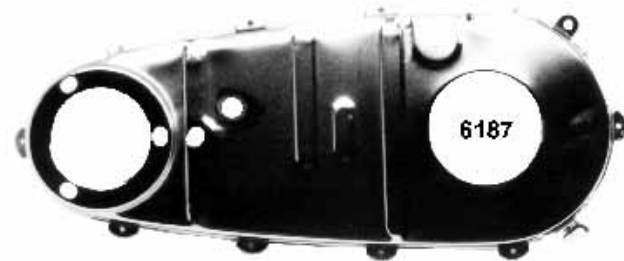
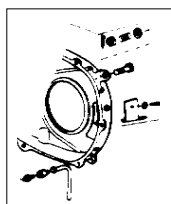

## Steel Inner Primary Covers 1936-84

1936-54 Covers have a small hole at motor end and 1955-69 covers have a large hole at motor end for a splined sprocket shaft. PCP# 19858 is slightly deeper allowing it to mount to 1965-69 motor cases. PCP# 6188 allows use of 1955-64 type compensator outercover on alternator types but electric start must be sacrificed.

PCP	Years	Finish
6186	1936-54	Chrome
19828	1936-54	Black
6187	1955-64	Chrome
19829	1955-64	Black
6188	1970-84	Alternator type

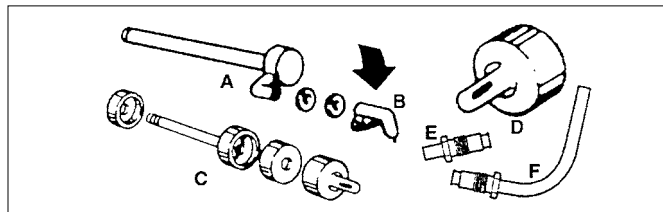

## BT Primary Breather Tubes

PCP	Description
10904	(A) Stud and oiler 1948-57 (24912-48A)
19308	(B) Snoot 1936-57 (24918-64)
17500	(C) Breather stud kit (all) 1958-64
1379	(D) Rubber Nipple 1958-64 (24918-58)
17506	(E) Tube with nut 1965-66 (24912-65)
17507	(F) As above, 1967 (24913-67)

# Sportster Primary



## Colony XL Primary Screw Sets

Cadmium Stock Type Screws

PCP	Application
9851	XL, XLH 1957-66
8891	XLCH 1964-69
8893	XLH 1967-70

Chrome Allen Type Screws

9753	XLCH 1957-69
5376	XLCH, XLH 1971-76
5379	XLCH, XLH 1977-85

Chrome Acorn Type Screws

1698	XLCH, XLH 1957-69
1723	XLCH, XLH 1971-76
1791	XLCH, XLH 1977-84

Chrome Cap Type Screws

2867	XL 1977-85
------	------------



## Filler and Clutch Caps

These chrome caps fit adjuster on XL 1977-84 models.

44098 Set



## Sprocket Shaft Extension XL 1974-76

43428

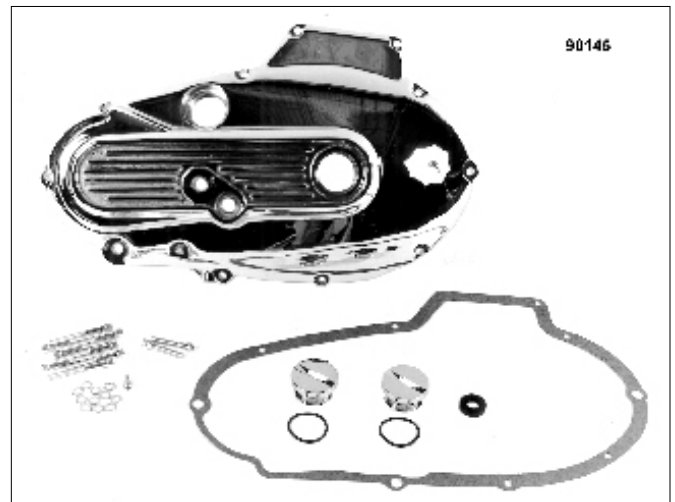

## Chrome Primary Cover Kit XLH-XLCH 1971-83

Kits include chrome die cast outer primary cover, inspection cover clutch adjuster cover, gasket and chrome allen screw set.

PCP	Application
90144	1971-76 generator
90145	1977-83 generator
90146	1984-85 alternator



## Primary Chrome Filler Cap & Clutch Hole Cap

XL Custom chrome plated steel caps have a 15/16 hex to facilitate installation and removal with a standard wrench.

1773	Filler cap 1971-76 (each)
1774	Clutch adjuster cap 1971-76 (each)
1779	Filler cap & clutch adjuster 1977-84 (each)
5367	Adjuster clutch hole & filler 1985-90 (2 needed) (ea)

## Chain Housing Needle Bearing

Use for starter drive. Replaces #9063. Use on 1965-88, 74", 1967-on XLH.

15609



# Sportster Primary

86019



86021 Chrome 1971-76 (34949-71)  
86019 Polished 1971-76 (34949-71)



4874 Chrome tin (Paughco) 1958-69 XLCH (34949-64)



86022 Chrome 1977-83 (34949-75A)



67648 Polished cover 1977-83 (34949-75A)



**Primary Cover Filler Cap & Clutch Hole Cap**  
Custom chrome plated steel caps have a 15/16 hex to facilitate installation and removal with a standard wrench. Now available for Sportsters 1977-84. 2 required per motor.  
1779 Each

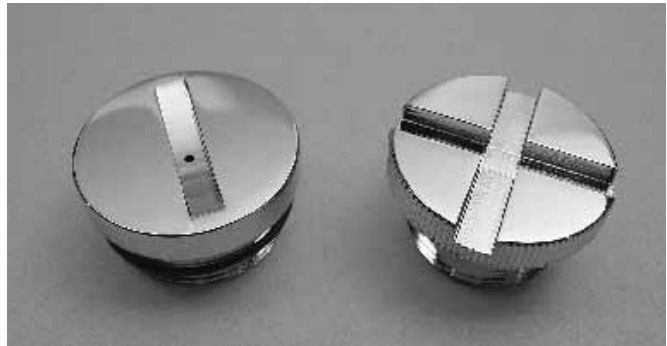

**XL Chrome Primary Cover Caps**  
44097 Set for 1971-76



# Sportster Primary

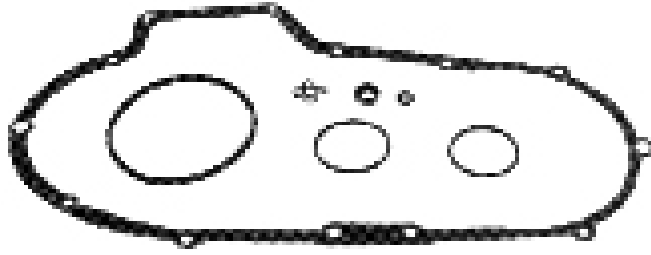

## James Sportster Chain Cover Gasket Kit

James	Description
79727	1977-90 (34955-75-K)
79728	1977-90 w/silicone (34955-75-X)



## Sportster Primary Gasket

James	Application
79341	.062 XLH, XLCH 1952-69 (34952-52-A) (10 pk)
79342	.020 XLH, XLCH 1967-76 (34955-67) (10 pk)
79343	.030 XLH 1967-76 (34955-67-A)(10 pk)
79344	.030 1977-90 (34955-75) (10 pk)



## Primary Cover Filler Cap

Reproduction of the original aluminum primary plugs to fit 1954-70 Sportster. Replaces 34742-52A and is available in chrome plated steel or aluminum.

72144	Aluminum
72145	Chrome

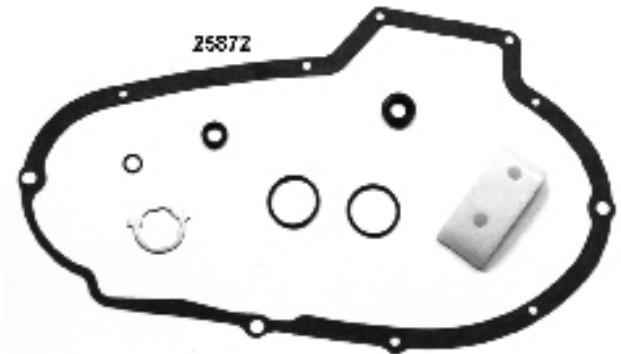

## Sportster Primary Kit

Includes gaskets and small parts.

PCP	Fits
25870	1967-76 XLH, 1971-76 XLCH
25871	1977-79 all models
25872	1980-89 all models

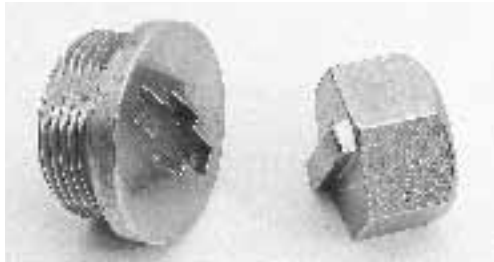

## Primary Cap Installation Tool

Use to prevent damage to primary caps on 1971-90 XL  
5800



## Inserts for Sportster Primary

Available in chrome steel supplied with an adhesive back, to fit in recess in aluminum primary cover. Each.

22197	Chrome 1971-76
-------	----------------

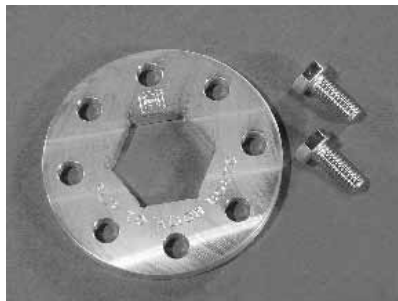

## Motor Sprocket Nut Lock Plate for XL 1967-90

Plate is held in place by 2 hex bolts which are threaded into the stock non-compensating sprocket. Constructed of aluminum.

12610



## Primary Cover Inserts (each)

Inserts feature an adhesive back and a foil accent for stock primary covers.

22198	1971-76 (1000) (34960-72)
22199	1977-84 (Sportster) (34961-77)

# Sprockets



## Taper Motor Sprocket Fits BT 1936-54

Steel sprockets, assorted sizes to accomplish the gearing you want.

PCP	# of Teeth
2486	22 (40209-30)
593	23 (40210-30)
594	24 (40211-30)
595	25 (40212-30)



## Compensating Sprocket

These sprockets fit FL late 1970-82; FL Classic 1970-81 and FX 1971-83.

PCP	Tooth
3279	23 (40282-70)
3282	24 (40275-70)

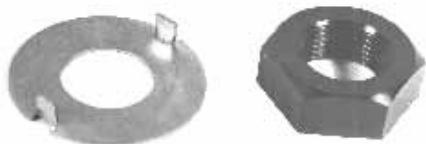

## BT Sprocket Nut and Locktab Set 1955-On

Locks nut by using 2 tabs which fit into sprocket holes when non-compensator sprocket is used.

12632

## Motor Sprocket Nuts

PCP	Application (Each)
12521	45 cu. in 1929-73 (7991)
12524	XL 1957-69 (8025)
12568	XL 1970-88 (40387-70)
12537	BT 1930-54 (24003-30)
12538	BT 1955-69 (24003-55)
12569	BT 1970-90 (40392-70)

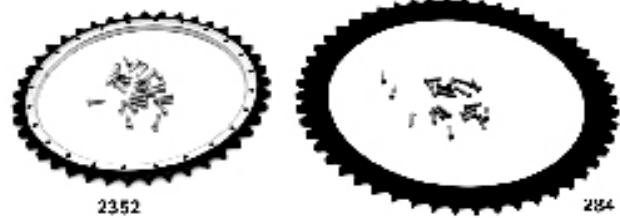

## Rear Brake Drum Sprocket Replacement Kits

Steel rear wheel sprockets. BT 51 tooth complete with rivets and dowel pins. Mechanical type, with rivets included. Hydraulic sprocket kit complete with 20 rivets.

PCP	Fitment
2352	1935-52 45 except Servi Cars (41747-35, 2043-35)
284	1957-78 XL, XLCH, XLH (4147-70)
257	1930-57 All BT except 1936-61 models (41470-30)
10141	1937-72 BT Brake shell dowel pins (41425-37) (5 pk)
4538	1958-61 FL, FLH, Hydraulic (41470-58)
254	1962-66 FL, FLH, Hydraulic (41470-62)
251	1967-72, FX, FL, FLH, Hydraulic (41470-67)



## Spline Motor Sprocket Fits 1955-on

Steel sprockets, assorted sizes, to accomplish the gearing you want.

PCP	# of Teeth
2485	22 (40209-55)
596	23 (40210-55)
597	24 (40211-55)
598	25



## Complete Rivet Dowel Pin Set

Especially made for drum brake, hydraulic and XL type sprockets. Cadmium plated, or black finish.

PCP	Fitment
285	Mechanical 1930-59
255	Hydraulic 1960-66
252	Hydraulic 1967-72
285	XL-XLCH 1954-78
5519	45 Solo 1935-52

# Sprockets



## USA Trans Sprockets

USA made transmission sprockets for all Sportster and Big Twin models from 1936-on. These sprockets are fully hardened for maximum service and performance.

### For Big Twin Models 1936-79

PCP	Tooth
5080	22 (35203-36)
5081	23 (35212-73)
5082	24
5083	25

### For Big Twin models 1980-85 (With 4-Speed Transmission)

PCP	Tooth
5085	22 (33338-83)
5086	23 (33337-83)
5087	24
1281	Sprocket spacer L1980-81 (35079-80)

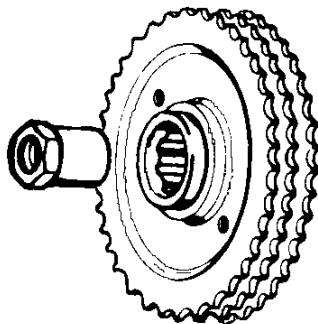

### XLCH Motor Sprocket-34 T

PCP	Description
43612	Sprocket 1954-69 (40288-58)
43613	Sprocket 1970-76 (40235-70A)
43614	Sprocket 1977-90 (40235-74)



## Heavy-Duty Imported Transmission Sprockets

High quality imported transmission sprockets, a lower cost alternative to our line of USA made transmission sprockets.

### For Big Twin Models 1936-79

PCP	Tooth
2487	22 (35203-36)
599	23 (35212-73)
600	24
601	25
1281	Sprocket spacer (35079-80)

### For Big Twin Models 1980-85 (With 4-Speed Transmission)

2489	23 (33337-83)
2490	24 (35212-80)
2491	25
1281	Sprocket spacer (35079-80)

### For Big Twin Models 1980-84 (With 5-Speed Transmission)

3621	22 (33336-83)
3622	23
3623	24



## USA Sportster & K 1954-E79

PCP	Tooth
5961	21 (35205-52A)
5962	22
5963	23
5964	24

### Sportster Models L1979-E84

5092	21 (35205-79A)
5093	22
5094	23

### Sportster Models L1984-90

5095	21 (35208-84)
5096	22
5097	23



## Offset Sprockets (1/4" offset)

Fits XL models which allows the use of a 150 series tire. Order rear sprocket spacer separately.

### 4 Speed 1984-90

PCP	Teeth
43622	19T
43623	20T
43624	21T
43625	22T



## BT Sprocket Nut Lock Screw 1980-90

Replaces 857A with nylon patch.  
24556 10 Pack



## Heavy-Duty Transmission Sprockets

### Sportster & K 1954-E79

Seal Side .435"	
PCP	Tooth
2484	20
603	21 (35205-52A)
604	22

### Sportster Models L1979-E84

Seal Side .500"	
2492	20 (35205-52A)
2493	21 (35205-79A)
2494	22

### Sportster Models L1984-90

4539	21 (35208-84)
4540	22
5965	23
5966	24

# Sprockets



## BT 1/4" Offset Rear Sprocket & Spacer Kit

This kit mounts wider rear tires on Big Twin 1973-85 4 speeds. Kit includes special 1/4" offset transmission sprocket, rear sprocket spacer plate and mounting hardware.

### PCP Teeth

43608 22T

43609 23T

43610 24T

**Note:** Kit is designed to ease the problems encountered on some custom applications. 1979-85 FX models will require modifications, including changeover to a Prestolite starter.

43503



43500



## Chrome-Plated Rear Sprockets with Cutouts

Slotted chrome rear wheel sprockets match the front brake rotors used on all 1984-on. For Big Twin 4 speeds 1973-85 and Sportster® 1979-81.

43503 51 tooth

## Chrome-Plated Solid Rear Sprockets

"Solid" chrome plated rear wheel sprockets. Fits all 4-speed Big Twins 1973-85 and Sportster® 1979-81

43500 51 tooth



## Solid Motor Sprocket Conversion Kit

The conversion kit replaces the compensator unit and sprocket. Includes nut.

### PCP Description

43617 24T FL 1970-84, FX 1980-84

43618 25T FX-FL 1970-84

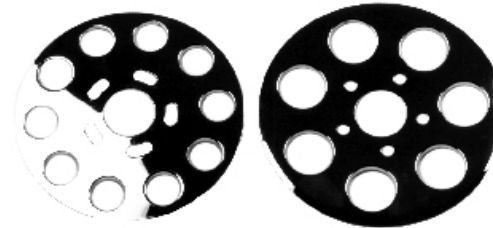

## Chrome Rear Chain Sprocket Covers

Sprocket covers for the stock rear sprockets on many Sportster® 1979-81 and Big Twin 1973-85. These steel covers are chrome-plated and install over the stock-plated OEM rear sprockets. Use your stock mounting hardware or Colony custom kits.

45801 Big Twin 4 speeds 1973-85 & Sportster 1979-81 51T

**Note:** The covers with holes listed above will ONLY fit Harley-Davidson® sprockets, and will require rotating them to the sprocket to get all of the holes to line up.



## Chrome 5-Spoke Sprockets

Offers a 9.8mm offset.

### Offset Teeth

59459 48

59460 51



## Chrome Plated Rear Sprocket Hardware Kit

Includes flat head allen screws, locknuts and companion countersunk washers. Fits 1973-on.

### PCP Application

9856 FL, FX, XL w/chain drive spoke rear (41197-73)

9857 FL, FX 1973-on, XL 1973-91 w/cast rear wheel including belt drive (3769). Locknuts not included.

# Rear Sprockets

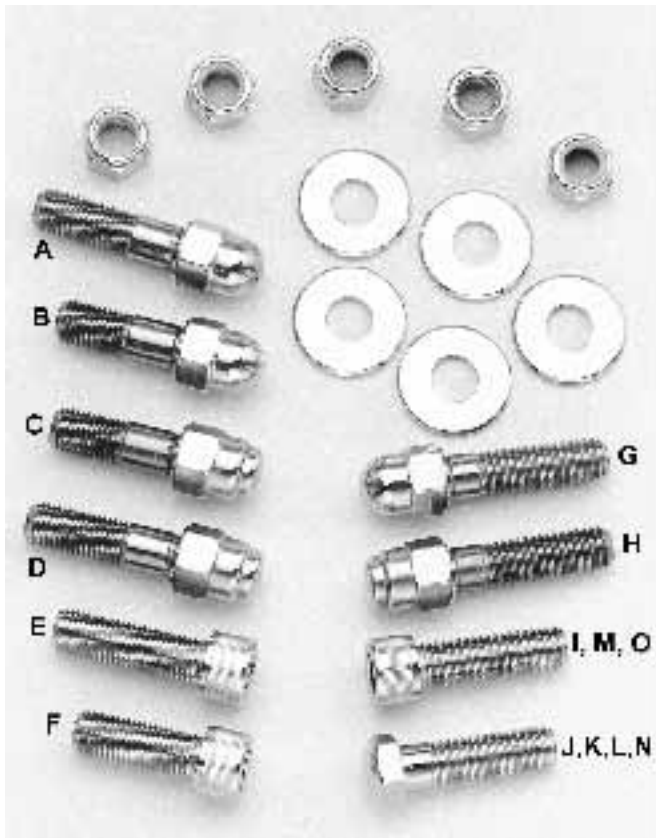

## CHROME PLATED REAR SPROCKET HARDWARE KITS

Sprocket bolt & nut Kit fits 1973-on FL, FX, XL with spoke rear wheel. 7/16x20, OEM# 41197-73

<b>4364</b>	B	Acorn style
<b>4365</b>	C	Cap style
<b>4368</b>	F	Allen style
<b>9609</b>	J	Domed hex style

Sprocket bolt & washer kit fits 1973-on FL, FX, XL with cast rear wheel including belt drive. 7/16x14, OEM# 3769

<b>4369</b>	G	Acorn style
<b>4370</b>	H	Cap style
<b>4371</b>	I	Allen style
<b>9608</b>	K	Domed hex style

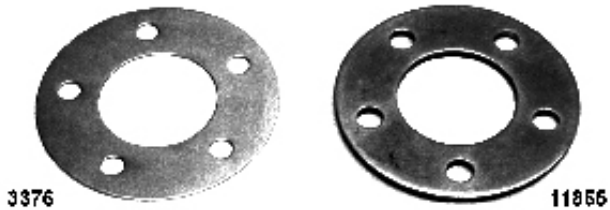

## Sprocket and Disc Spacers

Spacers provide offset when required.

PCP	OEM	Description	Thickness
<b>3376</b>	41814-76	1976-81	1/16"
<b>11855</b>	40932-81	1981-on	3/16"
<b>11856</b>	Allo	1973-on	1/4"
<b>11857</b>	Alloy	1973-on	5/16"
<b>11858</b>	Alloy	1973-on	3/8"
<b>11859</b>	Alloy	1973-on	1/2"

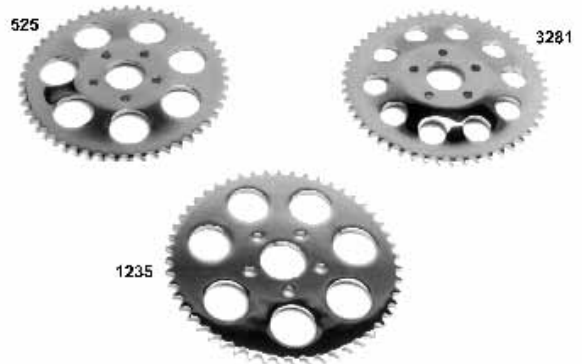

## Rear Disc Brake Sprockets

Various sizes are available in our rear sprockets for Big Twins 1973-85 and Sportster's 1979-81. Plain or chrome-plated.

### Plain

PCP	Tooth (Dished)
<b>524</b>	48
<b>3542</b>	49
<b>523</b>	51 (41470-78T)

### Chrome

<b>526</b>	48 (41470-78)
<b>2483</b>	49 (41470-73)
<b>525</b>	51 (41470-78T)

## Chrome Sprockets for FXR Models 1982-85

FXR models (except FXRT, FXRP) with rear chain drive.

PCP	Tooth (Dished)
<b>3549</b>	46
<b>5967</b>	47
<b>2543</b>	48 (40954-81C)
<b>3281</b>	51 (40954-83)

## Chrome Sprockets for Sportster's 1982-85

PCP	Tooth (Flat)
<b>3761</b>	48 (41470-82T)
<b>1235</b>	51 (41464-81)



## Chrome Laser Style Sprockets

Sprockets have a 13.8mm offset and feature a milled centre design. Sprockets fit FX 1973-on chain drive models.

PCP	Teeth
<b>59233</b>	48T
<b>59234</b>	49T
<b>59235</b>	51T

# Chain



## Standard

Diamond 530 standard is the mainstay of the motorcycle chain. It has been continuously upgraded by raw material selection, improved heat treating methods and innovative manufacturing and production techniques to keep it in step with the demands of today's motorcycles.

PCP	Size	# of Links
2642	530STD	100
2643	530STD	102
2644	530STD	104
2645	530STD	106
4641	530STD	108
2646	530STD	110
4642	530STD	112
4643	530STD	120
2647	Master links	(5 pack)

## Diamond Primary Chains

Endless link diamond chain for primary drive replacement on Big Twins, FLT and XL. Chain type links.

PCP	Size	Fitment
2657	428x2-82	1936-06 BT (not FLT-FXR) (40007-36A)
59480	428x2x80	Special length
2658	428x2-76	1979-06 FLT-FXR (40037-79)
2656	35x3-94	1957-03 XL
2654	35x2-96	1938-on Servi-Car
2655	35x2-100	1929-52 45 Solo
5528	428x2x88	1930-36 VL models (endless)

## XDL Self Lube

530 XDL eliminates the possibility of hit and miss lubrication, as it has a constant and consistent lubrication in the pin bushing (wear) area. This chain combines the high strength and capacity of Diamond's proven performance with the advantages of fewer adjustment and less maintenance.

PCP	Size	# of Links
2637	530XDL	102
2638	530XDL	104
2639	530XDL	106
4546	530XDL	108
2640	530XDL	110
4547	530XDL	112
4548	530XDL	120
2641	Master links	(each)

## Diamond Spare Parts Kit

Includes: 2 master links, 1 link and 1 offset link for all 530 heavy-duty chain.

4644 Spare parts kit



## BT Chain Tensioner Parts

PCP	Application	Year
24042	Complete kit	1965-on
24034	Hardware kit	
1190	Nylon pad	(39976-65B)
13731	Lock	(10 pack) (39996-65)
27113	Shoe mount bracket	(39990-65)
17502	Plate	(39993-65)
3747	Nut and anchor plate	(39992-65A, 39998-65)

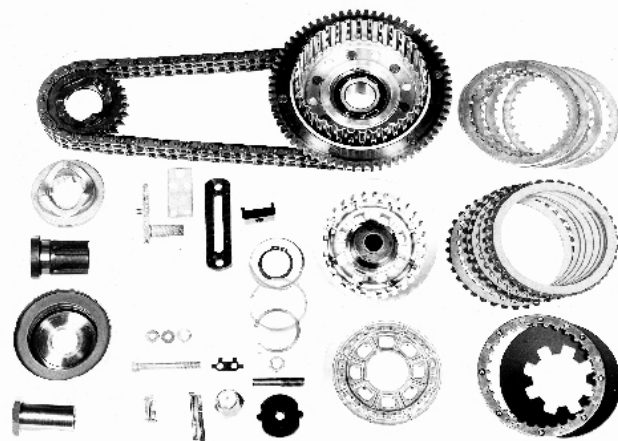

## Primary Chain Drive Systems for BT (Evo Shown)

Kit includes 76 or 82 link Diamond primary chain, chain shoe adjuster assembly, clutch drum basket with starter ring gear and steel & fiber clutch plates with pressure plate assembly. Correct front compensator sprocket assembly includes all parts necessary for installation, including sprocket nut. All pre 1985 FLH-FX 4 speeds require 82 link primary chains, 1980-on FLT-FXR 5 speeds require 76 link primary chains.

82 Links	76 Links	Year
53084	53092	1970-84



2650



4801

## 530ENP Nickel Plated

Diamond chains are also available nickel plated, which offers rust-proof protection along with a brilliant chrome-like finish. Each part of these nickel plated chains is individually plated before assembly to insure maximum coverage.

PCP	# of Links
2648	100
2649	102
2650	104
2651	106
4645	108
2652	110
4646	112
4647	120
2653	Master links (each)

## 530XLO Diamond O Ring Chain

The features contained within the linkplates of Diamond 530XLO include a .214 Diamond pin which has been produced using a special alloy steel and case hardened for optimum strength and toughness, heavy series inside and outside linkplates, special constructed extended solid brushings, true wall solid rollers, quad staked pin heading, a whopping 9300 lbs. average tensile strength.

PCP	# of Links
4800	102
4801	104
4802	106
4803	108
4804	110
4812	112
4813	120

## XLO Connecting Links

4788 Each

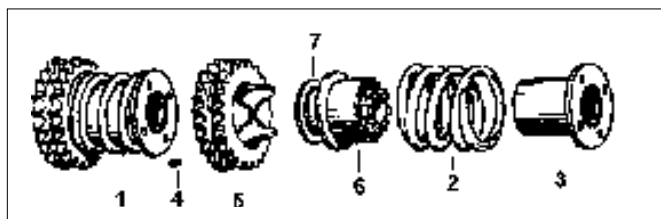

## Chain Breaker

Good for cutting 530 chain  
26039

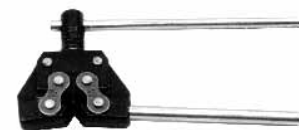

## BT Compensator Parts 1955-69

#	PCP	Description
1	29075	Complete kit
2	13244	Spring (40302-55A)
3	12624	Nut (40385-55)
4	10316	Key (40390-54)
5	29095	24T Sprocket (40275-55A)
6	29096	Slide cam (40292-55A)
7	29097	Sprocket shaft extension

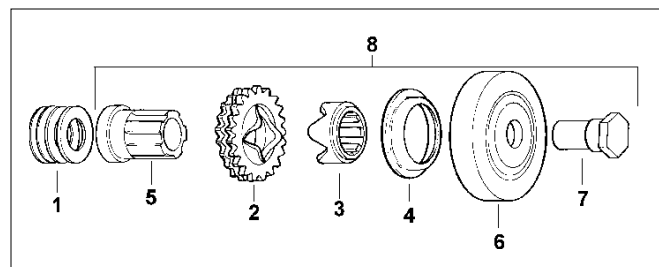

## Compensator FL, FX L1970-82

#	PCP	Item
1	11850	Spacer .010 (35850-84) (5 pk)
	11851	Spacer .020 (35951-84) (5 pk)
	11852	Spacer .032 (35852-84) (5 pk)
	11810	Spacer .060 (24032-70)
	11811	Spacer .090 (24033-70)
2	11812	Spacer .120 (24034-70)
	11813	Spacer .150 (24035-70)
3	11814	Spacer .180 (24036-70)
	11815	Spacer .210 (24037-70)
2	3282	Sprocket 24T (40275-70)
	3279	Sprocket 23T (40282-70)
3	29070	Slide cam 1970-83 (40299-70)
	43407	As above (Preston)
4	29071	Cup (40324-70)
5	29072	Extension (40375-70)
6	29073	Retainer & cover assy w/springs (40384-70)
7	12569	Nut (40392-70)
8	29074	24T Kit as pictured (no spacers) (40270-65A)

SPROCKET APPLICATION GUIDE						
Engine	Model	Stock Rear Sprocket*	Stock Front Sprocket*	Stock Ratio	Stock Chain	
900	XLH 1958-66	51	22	2.32	530-104	
	XLCH '58-59	51	22	2.32	530-104	
900 & 1000	XLH 1967-80	51	22	2.32	530-106	
	XLCH '70-80	51	22	2.32	530-106	
1200	FL, FLH '62-66	51	22	2.32	530-102	
		'67-72	51	22	2.32	530-102
		'73-78	51	22	2.32	530-102
1200	FX 1967-72	51	22	2.32	530-102	
		1973-78	51	23	2.22	530-102
		FXS '73-78	51	23	2.22	530-102

# Chain Related

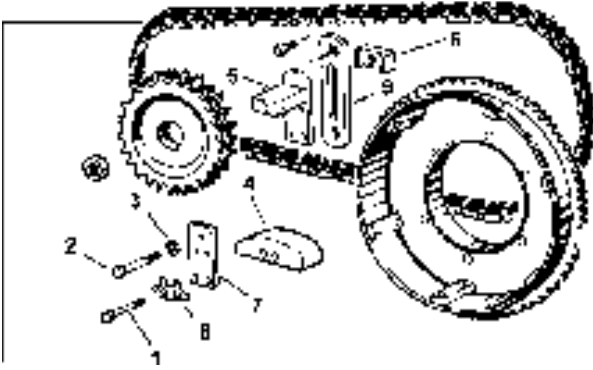

## Chain Tensioner Parts

Items listed below fit 1965-84 4-speed Big Twins.

PCP	Type
24034	(1, 2, 3, 4, 7, 8) Hardware kit
1190	(4) Nylon pad (39976-65B)
13731	(8) Lock (39996-65) (10 pack)
27113	(5) Shoe (39990-65)
17502	(7) Plate (39993-65)
3747	(6,9) Nut and anchor plate (39992-65A, 39998-65)



1190



3747

## Nylon Primary Chain Shoe Adjustor

Replaces OEM #39973-65 lining. Also No. 39976-65B tensioner shoe. Use on 1965-00 74", 80".

1190

## Tensioner Anchor Plate

Replaces plate 39998-65, and nut 39992-65A on FX-FL 1965-on, heat treated detents for positive hold.

3747



## Sifton BT Hydraulic Primary Chain Tensioner

Features a hydraulic valve which controls the motion of the submerged piston which constantly keeps the chain in tension for 1965-on BT.

59964



43112

## Rear Chain Tensioner

Use of tensioner reduces chain vibration and frequency of adjustments. Tensioner features a durable urethane roller which revolves on sealed bearings mounted on chrome anchor plates.

PCP Description

43112 FL, FLHS, FXE, FXWG 1973-85

43113 XL, XLH 1957-on

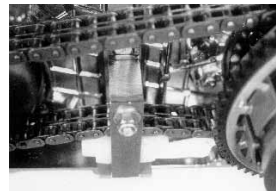

43400

## Self Adjusting Chain Tensioner Kit

Fits Big Twins 4 & 5-speed 1965-on replacing factory type detent adjuster shoe. Kit includes all hardware and detailed instructions for the complete conversion.

43400 BT 1965-00

43402 XL 4 speed 1977-90

43401 Replacement shoe



43110

## Rhino Foot Primary Chain Adjusters

Adjuster comes complete with bracket, sprocket with needle bearing and hardware.

43110 FXR series short case 5 speed (RFT2)



# Chain Related

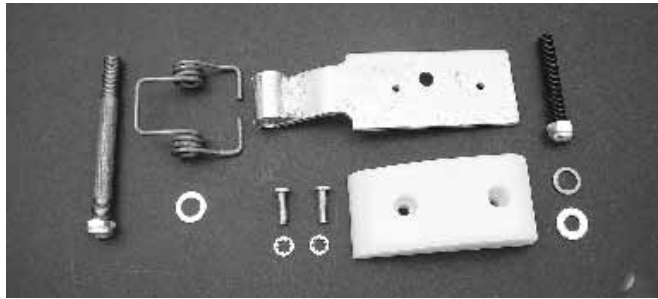

## Sportster "Primary Adjuster Shoe Kit"

Fits 1979-85, OEM on 1980-85, use to update 1977-79.

**60000** Kit as required 1977-85

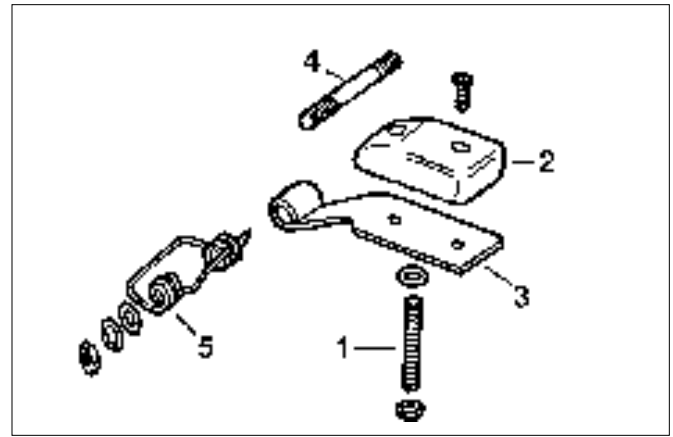

## Sportster Primary Adjuster Shoe Components

#	PCP	Item
1	10902	Adjuster stud 1977-90 (each) (3250)
2	3276	Pad 1980-90 (39966-80)
3	60002	Carrier 1980-90 (39973-86)
4	10858	Stud 1977-85 (40018-77)
5	13197	Spring 1977-85 (40019-80A) (each)

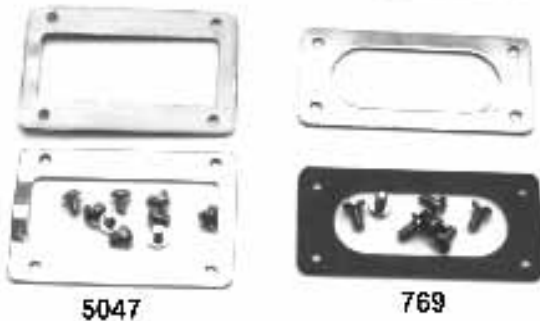

## Axle Plates

Made of polished stainless steel to protect axle area. (Pairs)

### PCP Models

**43001** FXR-FXRS 1982-on

**5047\*** Rigid BT 1936-72

**769\*** FX-FL, BT 1973-83 and XL 1979-on

\* Requires drilling and tapping at axle area (drill and tap not included), but includes screws.

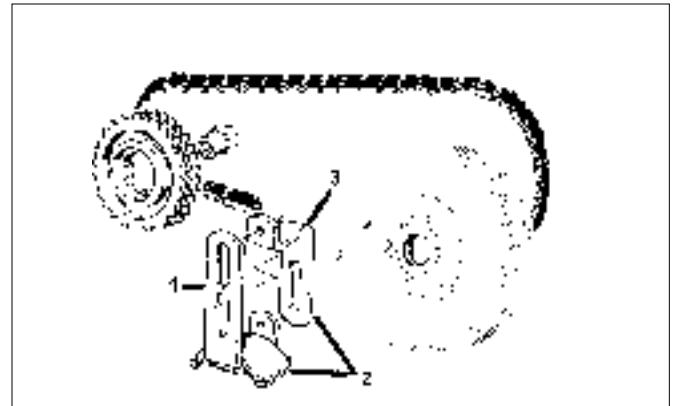

## Sportster Chain Tensioner

Includes pad and clip replaces 39975-54A on 1957-69 XLCH models, or 39975-54B on 1971-79 XLH-XLCH which includes 39980-54 brace.

#	PCP	OEM
1	43420	39975-54A
2	43421	39975-54B (2 pc.)
3	43422	Offset Bracket 39980-54



## 1958 Style FLH Rear Chain Guard

Fits FL 1958-84. Replaces 60302-58.

**85024** Black

**85025** Chrome

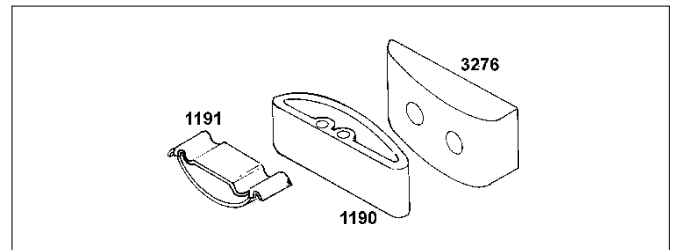

## Nylon Primary Chain Shoe Adjustor

PCP	Description
1191	XLH-XLCH 1957-79 (39978-58A)
1190	FL-FLH-FXE 1965-00 (39976-65B)
3276	XLH-XLCH 1980-90 (39966-80)

# Chain Guards

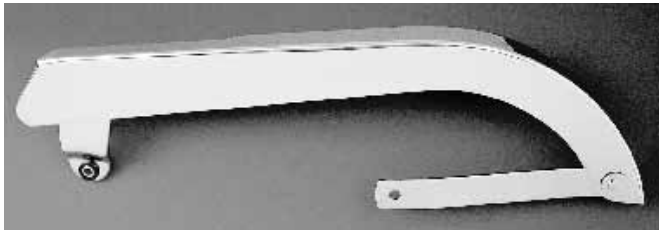

## Chrome Iso Mount Swing Arm Chain Guard

Use on all FLH-FXE-FXR models 1958-on chain drive models. Includes rubber bushing & rear bracket.

PCP	Application
451*	FX-FL-FXE 1958-85, FXWG 1980-84 (60302-73T)
6343	FXR 1982-84 (60607-81A)
24084	Mount kit

\*Note: Also fits FL models 1958-84 for the FX look.



## Chrome Chain Guard

For 1958-82 FL and Super-Glide FX. Bracket included. Also fits FL models 1958-84 for the "lighter" FX look.  
6350



## Chrome Rigid Chain Guards

PCP	Model
6349	BT 1936-57 (60302-36)
5529	45 Solo 1936-52 (60303-36)
5530	45 Solo, raw (60303-36)
82020	As above black powder
82019	L/S universal layer type for custom mount
3176	As above, right side

## FLH Style Chain Guard 1958-62

Fits FX and FL 1958-84 and replaces 60302-58.

85023	Chrome
85022	Black

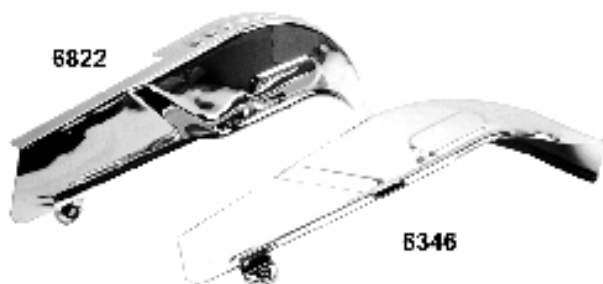
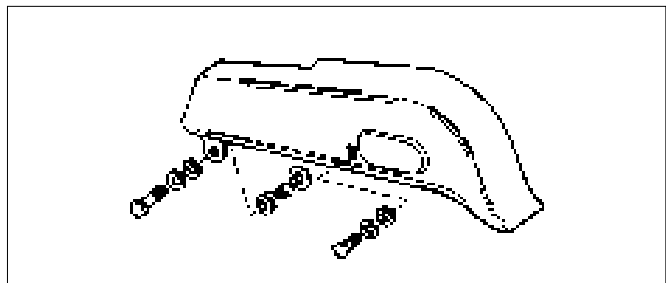

## FLH Style Full Chain Guard

Includes bushing

PCP	Description
6346	Chrome FL 1963-84 (60302-63T)
6822	As above, louvered
85021	Black FL 1963-84 (60302-63)
23021	Bushing (11411) (5 pack)



## FLH Bushing Kit

Fits FLH chain guards 1963-84, includes one of each 11411, 5926B and 6107B for one guard.

PCP	Description
24035	Bolt and bushing kit
23021	Bushing only (11411) (5 pack)

# Chain Guard



## Chrome Rear Belt Guards

**6348** 1980-86 FXB-FXSB (60388-82)



## Rear Chain Adjusters

Adjusters are heat treated and plated. Sold in pairs with plated lock nuts and assembled to insure properly fitting threads.

**5165** BT 1936-72 Cad  
**1796** BT 1936-72 Chrome  
**1632** 45's 1930-52 Chrome  
**5246** 45's 1930-52 Cad

## Rear Chain Adjusters

Chrome XL adjusters with lock nuts.

**1337** All XL 1954-78  
**5128** Colony as above

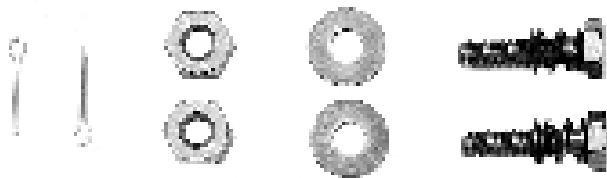

## BT Rear Chain Guard Mount Kits

Kit includes bolt, nut, spring, cotter pin and washers.

**PCP** **Description**  
**9601** BT 1936-64, parkerized

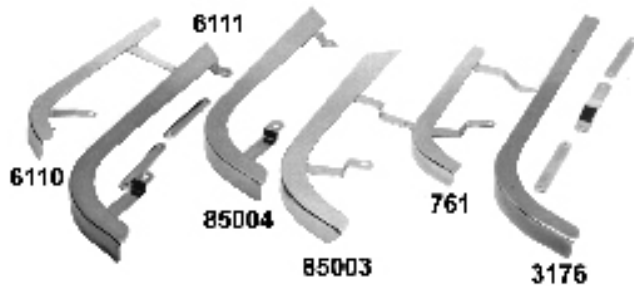

## Chrome Chain Guards for Sportster

PCP	Model
<b>6110</b>	1956-71 XLH (60308-67)
<b>6111</b>	1956-71 XLCH (60303-56)
<b>85004</b>	1972-78 XLCH (60308-72)
<b>85003</b>	1972-78 XLH (60344-72)
<b>761</b>	1979-81 XLCH-XLH (60375-79)
<b>3176</b>	Universal right side, 25"L

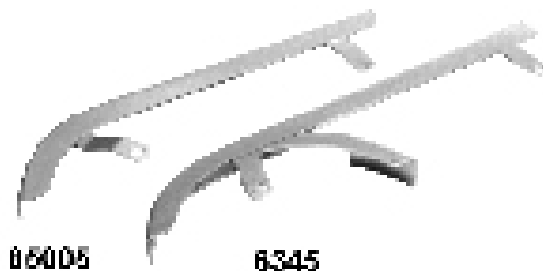

## Chrome Chain Guards for Sportster

PCP	Years
<b>85005</b>	1982 only, without apron (60387-82)
<b>6345</b>	83-87 with splatter apron (not 87 Hugger) (60375-83)



## Rigid Replica Chain Guards

Come complete with stud for mounting to stock rigid fender.

PCP	Application
<b>82017</b>	BT 1936-57 black
<b>82018</b>	As above, chrome
<b>82068</b>	BT 1941-57 black
<b>82069</b>	As above, chrome
<b>82058</b>	BT 1936-40 black (3 rivets)
<b>82070</b>	As above, chrome

# Chain Adjusters



## Custom Axle Adjusters (Pairs)

**43100** FXR models 1984-91

**43101** Heavy-duty axle adjuster blocks prevent swingarm body collapse due to overtightening. Fits 4-speeds 1973-on, FLT 1980-83, FXR 1982-on & XL 1979-on (41570-77)

## OEM Style Axle Adjusters (Pairs)

**3547** FXR 1982-on and FLT 1980-83 (41570-77, 41112-79, and 7725)

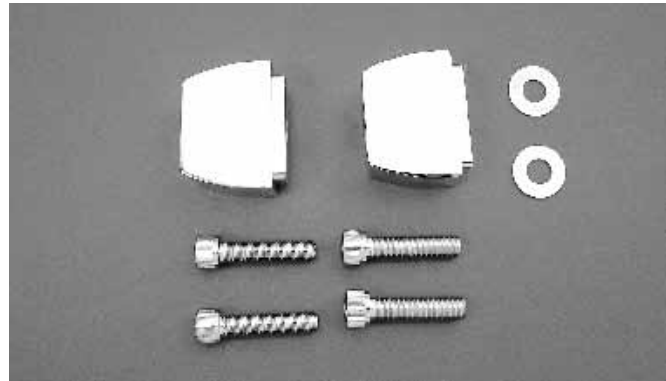

## Calibrated Rear Wheel Adjusters

Adjusters have chrome pyramid blocks with sight indicator to view calibrated adjuster bolt. Bolt is a heavy duty 1/2" rod with micrometer markings. Complete with chrome bolt and stainless steel nut.

**43108** FX-FLH 1973-85, XL 1979-on



## Complete Rear Wheel Adjuster

Complete kit contains adjusters; chrome plated end plates, hex nuts, and custom chrome plated tapered lock nuts.

**1778** Fits BT 1973-on

Chrome plated end covers and nuts replace the original equipment.

**1802** Fits BT 1973-84, XL 1979-87.

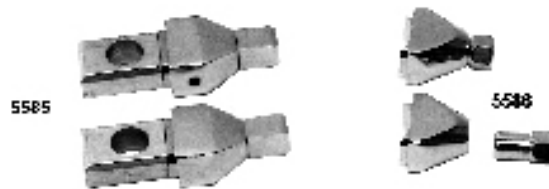

## Pyramid Adjuster Blocks

Chrome, die cast for positive adjustment. Includes nuts. For BT 4 Spd. 1973-86 and XL 1979-96.

**5585** With pull adjusters as pictured

**5586** Chrome outer parts only (use your stock adjusters) (41532-89T)

## Chrome Rear Wheel Adjusters

BT 4 speeds 1973-on, XL's 1979-on. Set of 2.

**2504** 41530-84T

