

Section 11A

Oil Tank

| | |
|-----------------------------|----------|
| Caps & Dipsticks | 2,8-9 |
| Filters/Breathers | 8-12,16 |
| Guage Kits | 7 |
| Hose/Clamps | 13-14,18 |
| Oil Coolers | 16 |
| Oil Line | 18 |
| Oil Line Accessories | 18 |
| Oil Tanks and Covers | 2-6 |
| Pressure Gauge | 7-8 |
| Stainless Steel Lines | 13-14,18 |
| Temperature Gauge | 7 |

Oil Tanks



FL/FX Chrome Oil Tank

An exact reproduction of the original oil tanks for all FX and FL model 4 speeds 1965 on. Part #6257 is fitted with the pre-'82, larger diameter filler opening, the tank accepts the OEM style in-tank filter. Kit #77952 includes tank, cap, filter and mount kit.

| PCP | Description |
|--------|--|
| 6257 | Chrome oil tank BT 1965-80 (62504-65B) |
| 77958 | Black, as above |
| 77952 | Chrome oil tank kit 1965-80 |
| 77976* | Chrome oil tank 1981-82 (62483-81) |
| 3296 | Chrome oil tank cap BT 1958-82 (62610-52A) |
| 77005 | Chrome oil tank plug |
| 939 | Chrome oil tank 5" temperature dipstick (62635-79T) |
| 77955 | Chrome oil tank BT 1982-86 (No filter cavity) (62504-82) |

*Note: Fits up to 1985 and accepts internal canister. Pre 1981 tanks use #3107 battery carrier. 1981-86 use #28921 Battery carrier.



Rubber Mounting Studs

This is just the answer for custom builders. These studs are perfect for mounting gas and oil tanks.

1154 10 Packs (62563-65)



Oil Tank Trim for Harley

This chromed aluminum trim conceals the stock oil tank seam on all Big Twin 4-speed models 1965-84. Available plain or with our 24K gold wing emblem.

| | |
|------|-------------|
| 2429 | Plain |
| 3047 | With Emblem |

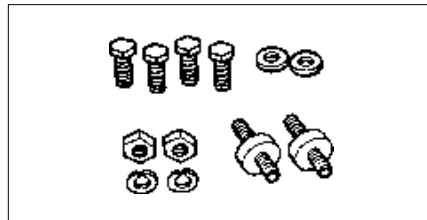

FXE, FLH Oil Tank Mount Kit 1965-84

Zinc plated bolts and hardware to mount tank to frame and battery box.

24065



Chrome Oil Tank Cap Assembly for Harley

Fits the original style oil tank on all Harley 4-speed models to 1986, FL 1965-82 and 1954-78 XL.

| | |
|-------|----------------------------|
| 3296 | Cap (62610-52A) |
| 79452 | Gasket 1966-E82 (62628-66) |

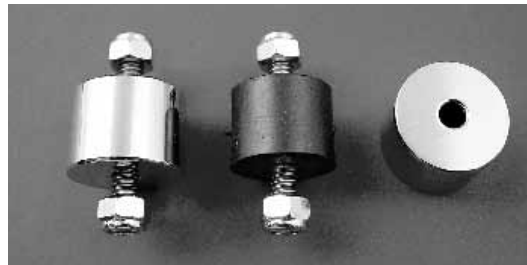

Chrome Iso Mount Kit

Kit includes two 1/4 x 20 Iso mounts and two chrome billet covers.

| | |
|-------|---------------------------|
| 44157 | Kit |
| 44069 | Chrome covers only (pair) |

Oil Tanks



Santee Wrap-Around Tank—Kickstart BT

Our custom smooth Wrap-Around Tank features 3-1/2-quart capacity. Acts as replacement tank for 1936-57 Big Twin rigid frames, and is adaptable to most custom rigid frames using original or reproduction tin primaries (without electric start). Takes stock 6-volt battery or our battery 6875 (12V). See oil lines elsewhere in this section.

6256



Chrome Wrap-around Oil Tank for Big Twins

Great looking oil tank installs easily and houses the stock FXE battery. The inner compartment lets you lift out the battery without removing the tank. Includes chrome nipple type hose fittings and filler cap. Full four-quart capacity. Fits all FX and FL 4-speed models 1965-83.

6258



Horseshoe Tank with Battery Box for 74"

Tank fits all rigid frames, hardtails, and swingarm applications. Has battery area measuring 4-3/8" wide and 5-3/4" long. 3-1/2-quart capacity, chrome wrap-around oil tank for all kickstart rigid frames, hardtails and swingarm 4-speed applications. Will not work on models with aluminum primaries. Features include easy-fill side spout, an integral "mousetrap eliminator" bracket, built-in battery tray and rear fender mount.

6254

Oil Tank Super Cap

77005 Fits all oil tanks



4-Quart Smooth Wrap-around Oil Tank

Designed for use in most custom rigid frames. It can be used with aluminum primary and electric start, and will accept stock FXE battery. *This oil tank will not fit stock original equipment rigid frames*, and requires #850 battery plate brackets to mount a fender. Comes complete with cap and fittings for threaded oil lines.

6260 Oil tank (for 4-speed)

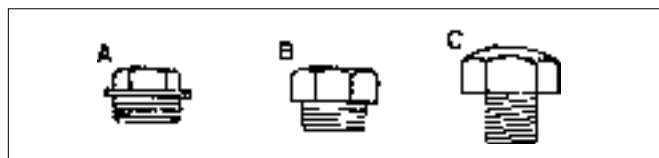

Drain Plugs

A. Fits oil tank drain with 5/8"-18, trans oil fill on 45's to 1940

3591 Chrome

5282 Cad

5283 Black oxide

B. Fits XL trans, motor, oil tank and BT 1937-86 trans. 1/2"-13

5259 Chrome

5260 Cad

C. Chrome plug with gasket for 1981-* BT with 1/2"-20.

5258

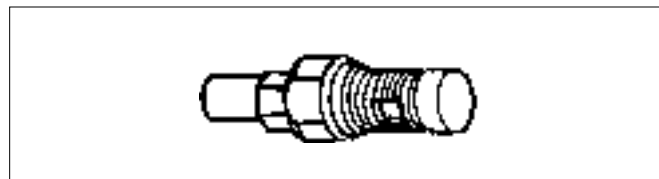

Oil Drain Valve Made in USA

These valves are made from '6061' alloy and is offered in a natural finish. Remove your stock drain plug (5/8-18TPI) and install the alloy unit (tighten 3/4"). Attach a 1/2" i.d. oil drain hose (from fitting to oil collection pan) and loosen fitting and oil begins to drain. After draining tighten fitting until it is seated and remove the drain hose. Oil draining is done with the 1/2" wrench surface.

10524 Each

Oil Tanks



Custom Oil Tanks (Unfinished)

77974 XL Custom 3 quart oil tank for use with XLH battery



Hex Wrap Around Oil Tank

Tanks install on FX, FL swing arm frames 1965-84 and houses the stock FXE battery (PCP# 6881), and allows for removal of battery without removing the tank from the frame. 3.5 quarts.

77956 With drain plug



Smooth Wrap Around Oil Tank

Tanks install on FX, FL swing arm frames 1965-84 and houses the stock FXE battery (PCP# 6881), and allows for removal of battery without removing the tank from the frame. 3.5 quarts.

77962 Can only be used with Hitachi type starter motor. (Paughco)



Oversize Drain Plug and Tap Kit

Contains 1 chrome plated dome head plug with an oversize thread and one tap for rethreading the stripped out drain hole. Fits O.H.V. Big Twin Harley Engines 1965-on.

1760 Kit

1761 Oversize drain plug only

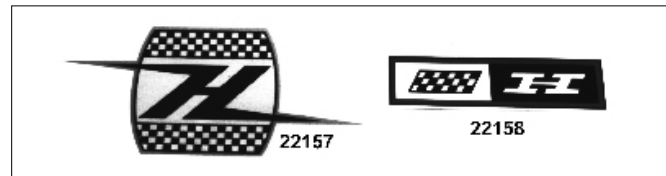

Oil Tank Decals

FLH style, adhesive decals. Sold 5 pack.

| PCP | OEM | Description |
|-------|-----------|------------------|
| 22157 | 62535-61A | H (62535-61A) |
| 22158 | 62535-65 | H-Bar (62535-65) |



FXR Oil Tank 1982-90

77961

Adhesive Patent Logo Decal

22100 Flat (99353-82Z) (each)





Santee Electric-Start Wrap-Around Tank for Sportster

This 3-1/2-quart oil tank will accept stock FXE or 1979-up XL electric-start battery (OEM 65991-75C). Fits all 1967-78 stock electric-start Sportsters. (On 1973-78 stock frames, the removal of the rear frame support struts may be required.) Includes cap, fittings, and mounting hardware.

3065 Oil tank

Custom Oil Tank Brackets for Sportsters

3064 Required when mounting Oil Tanks on custom rigid or swing-arm Sportster frames with behind-the-transmission single downtubes. Sold each.

Santee Horseshoe Oil Tank for Sportster

Tank features top/side-fill spout for convenience in adding oil. Offers a capacity of approximately 3-3/4 quarts. Includes cap, fittings, and all necessary hardware to mount stock 1958-78 Sportster frames without a battery. (On 1973-78 frames, the removal of the rear frame support struts may be required.)

3060 Oil tank



XLH Oil Tank 1967-78, Electric Start

PCP Description

- 3016** Chrome Sportster oil tank (62507-67A)
- 77946** As above, primered (62507-67A)
- 3296** Chrome oil cap assembly (62610-52A)
- 79451** Cap gasket 1952-65 (62628-52) (10 pk)
- 79452** Cap gasket 1966-82 (62628-66) (10 pk)

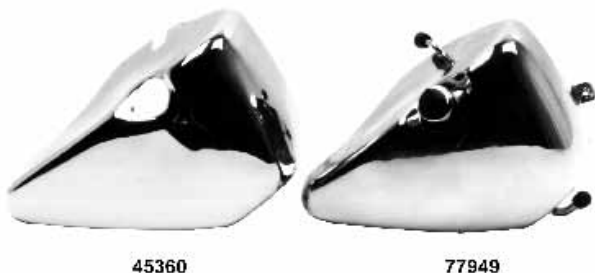

XLCH Chrome Oil Tank

Tank fits 1970-78 XLCH with kick start in rigid or stock frame. Includes chrome fill plug and top mount in place. Lower mount is available seperately.

PCP Description

- 77957** Tank (62508-73)
- 16202** Chrome lower bracket 1973-76 (62555-73)
- 27112** Black upper bracket 1973-76 (62554-72)

XLCH Front Oil Tank Mount

Fits 1953-65 and is zinc plated.

27330



Chrome Oil Tank For Late Sportster® Models

A great looking part that adds bright chrome to the right side of all Sportster® models from 1983-on. A copy of the OEM part, a one piece form fit cover is also available.

PCP Description

- 77948** Black tank 1983-93 883-1200 (62475-83)
- 77949** As above, chromed
- 45360** Chr. cover 1983-93 attached by springs
- 77007** Dipstick 2 5/8" 1982-on (62595-82A)
- 45360** Chr. cover 1983-93 attached by springs



Chrome Electric Start Oil Tank

Fits electric or kick start models 1967-78. Tank utilizes stock mounts for installation. Designed to fit with 12N164B batteries. Some 1973-78 models may require strut brace modification.

77984

Oil Tanks



77953



77966



77954

Original Type Oil Tank

OEM Type wrap around style with all seams welded and formed as stock. Available in chrome finish replaces 62504-58, with battery rod tab supports. Includes dip stick-cap. Fits 1936-64 Big Twins.

77965 Chromed tank with top fill cap, 1958-64

77966 As above with primered finish

77968 Chromed tank with side fill cap, 1958-64

77967 As above with primered finish

77953* Chromed tank with top fill cap, 1936-57

77954* As above with primered finish

* Without battery rods



6875

4682

Battery Extension Box

Battery box for 12 volt mini battery. Raises 12N5.53A to height of the old 6 volt battery. Use in old oil tank to regain original height so stock rods may be used. USA made includes rubber pads.

4682 Battery box conversion

6875 Short custom battery



1551

9205

Oil Tank Mounting Kit

Cad plated reproductions of stock hardware used to mount the oil tank on Big Twins 1936-64

1551 Kit

Oil Tank Bracket to Frame Mounting Kit

This kit contains reproductions of the stock hardware used to mount stock oil tank at rear, above swing arm on all Big Twins 1958-64.

9205 Chrome plated

9206 Cad plated

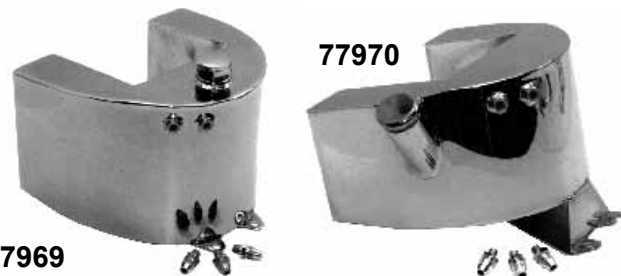

77969

77970

Paughco Horseshoe Oil Tank

3-1/2 Quart replacement tank for 1936-64 rigid swingarms. Accepts 6 volt battery and original or braided oil lines. Fits with a tin inner primary only.

77969 Centre fill, smooth

77970 Side fill, smooth

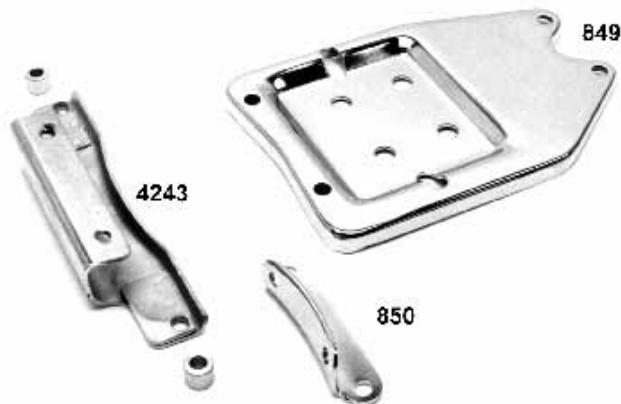

4243

849

850

Rear Oil Tank Support

Replaces 62584-58 on FL 1958-84 swing arm frames to mount wrap around oil tanks.

4243 Chrome support (62584-58)

849 Chrome oil tank plate for horseshoe oil tanks

850 Chrome fender to battery plate bracket.



Electric Start Wrap Around Oil Tank

Tank fits 1965-84 Big Twin 4 speeds. Tank features 4 quart capacity, built in FXE type battery box and accepts braided or rubber lines by your choice of fittings.

PCP Application

77971 4 Speed oil tank (shown)

77972 4 Speed oil tank with spin-on filter

4243 Rear bracket 1958-64

10614 Drain plug, magnetic

2501 Chrome replacement filter

Oil Gauges

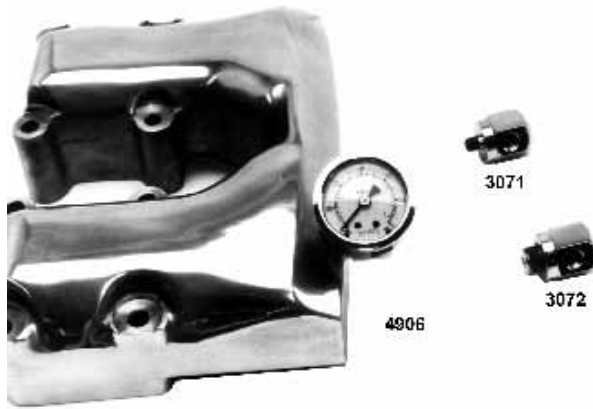

Nugget Oil Gauge Kit

Original hex design to place oil gauge at rocker box level on 1977-85 Sportster and 1966-84 Shovelheads. Sold as kit with 60 lb. liquid filled gauge. Hex dome matches our rocker shaft end plugs.

- 4906** 1971-84 Kit
- 3071** 1957-70 Fitting only
- 3072** 1971-84 Fitting only



“Revolution Cycle” Oil Pressure Adaptor for Big Twin Shovel

This trick item is manufactured from 6061 T6 aluminium and is offered in 2 versions and 2 finishes. 1 hole adaptor is for a pressure gauge & 2 hole adaptors are for a pressure gauge and the stock sending unit. Easy to install. Use teflon tape on the threads and tighten to the nine o'clock position for the stock oil light gauge. Stock exhaust with cross-over tube may interfere.

2 Hole for Light Unit & Pressure Gauge

- 27100** 2 hole version (clear anadize)
- 27101** 2 hole version (black finish)

1 Hole for Pressure Gauge Only

- 27102** 1 hole version (clear anadize)
- 27103** 1 hole version (black anadize)

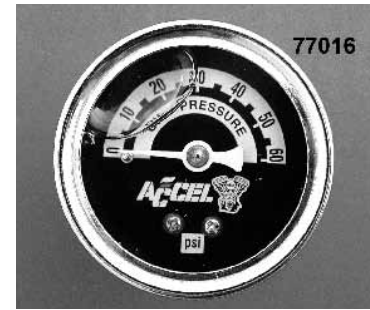

Accel Oil Pressure Gauges 60#

Liquid filled gauges feature a stainless steel case, 1-1/2" face, 1/8 NPT male rear fitting. Order fittings separately. **77016**



Sifton Oil Pressure Gauge Kit 1970-84

Includes 0-60lb gauge and chrome fittings.

- 77000** Kit
- 77001** Gauge only

Oil Plug Temperature Gauge for Stock 1965-86

This highly accurate gauge quickly responds to oil temperature up to 350°F. Fits 1970-84 FL, 1980-86 FLT, 1971-85 FX, 1982-83 FXR, 1970-78 XLCH. Fits most stock and custom tanks for most models with plug-in oil cap.

- 939** 5" (62635-79T)



Liquid Filled Oil Pressure Gauge

A 1-1/2" diameter oil pressure gauge with a stainless steel case and glass lense. Measures the oil pressure from 0-100 PSI. Each gauge is complete with fittings.

- 3833** Big Twins 1968-83 (stock exhaust with crossover tube may interfere)

Gauges/Filters



Oil Pressure Gauge

Chrome or stainless steel case and rim house available either liquid or air filled 60 or 100 lb. with 1-1/2" face, 1/8" NPT male rear fitting. Black face gauges have a 1.600 body and 1.960 rim. Stainless gauges have a 1.580 body and 1.735 rim.

| PCP | Pounds | Type |
|-------|--------|-------------------------------------|
| 77014 | 0-60 | Liquid, black with chrome body |
| 77012 | 0-100 | Liquid filled |
| 77013 | 0-100 | Air filled |
| 77018 | 0-60 | Liquid filled, S.S. with white face |
| 77019 | 0-100 | Liquid filled, S.S. with white face |

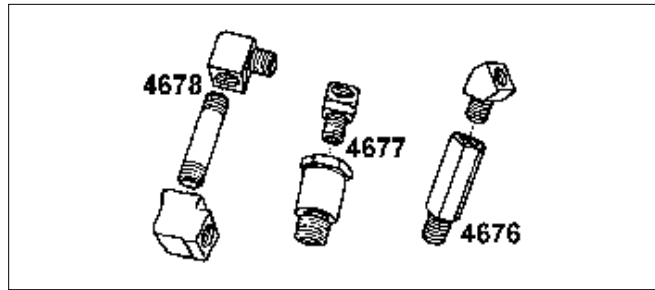

Oil Gauge Fittings

Accepts standard oil gauge with 1/8 NPT.

| | |
|------|--------------------|
| 4676 | 1941-67 74 & 80 BT |
| 4677 | 1968-84 74 & 80 BT |
| 4678 | 1957-84 XLH |

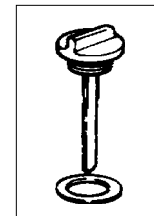

BT Dipstick 1936-64

| PCP | Description |
|-------|-----------------------|
| 19371 | Zinc cap (62625-36) |
| 19370 | As above, chrome cap |
| 79451 | Cap gasket (62628-52) |



Chrome Maltese Oil Caps

Fits 1970-78 tanks.

| | |
|-------|--------------------|
| 59305 | Oil plug all years |
|-------|--------------------|



Oil Pressure Gauge 0-60#

Liquid filled with 1-1/2" face, stainless steel bezel and chrome body. 1-3/4" body OD. Black face features V-Twin emblem.

77011



Oil Tank Cap & Dipsticks

Are rubber plug-in type with chrome cap to fit stock or custom tanks. Dipstick type replaces 62625-70 for use on FL FX 1970-on, XLCH 1970-78, with level markings.

| | |
|-------|----------------------|
| 77005 | Chrome plug |
| 77006 | Dipstick (62644-84T) |

Oil Filters



Original-Style Accessory Oil Filter System

Exact chrome replacement for 63800-48 on BT 1948-64 and can use the OEM bracket and stock steel oil line and fitting sets. Filter can be fitted to 1965-84 FL and FX models by use of bracket #2682 or on FXST 1984-on with bracket 3321. Oil lines must be fabricated for these applications. Order brackets, lines and fittings separately. Features slip on hose fittings which can be substituted with screw in fittings to accept metal lines.

PCP Fits

- 3293** Chrome oil filter assembly includes complete gasket kit and filter element (63800-48 and 63800-58)
25606 Complete gasket kit for oil filter assembly
3290 Filter element (sold each) (63840-48A)



Preston's Chrome Magnetic Oil Filters

A magnet located inside filter removes tiny ferrous particles that other filters can't. Low restriction filter has an increased element area and a built in pressure valve that provide increased flow and dependability.

PCP Application

- 77230** Short, BT 4 speeds 1982-86 with factory spin-on filter, XL 1980-E84 (63782-80)
77231 Long, FLT, FXR 5 speed 1980-98, XL L84-on and most OEM filter kits (63796-77)
77232 XL L1984-on (63813-90)



Chrome Oil Filter Mounting Brackets

Each of these all-chromed, steel brackets mounts an accessory oil filter. They were designed for use in conjunction with oil filter kit #3293. Available for both rigid and swingarm original equipment 4-speed frames.

PCP Fits

- 3294** 1950-1957 rigid frame Big Twins (63860-50)
3299 1958-1964 swingarm Big Twins (63860-58A)
2682 1965-1986 4-speed Big Twins except FXR & Softails (oil lines must be made)



XL Oil Dipsticks 1982-on

- 29210** Chrome (62734-96A)
29211 Satin (62735-96)



Crankcase Breather Assembly

Mount your breather in plain view instead of hiding it behind your engine or transmission case. Comes complete with a one-piece filter molded to a lightweight chrome end cap, a chrome zinc die-cast mounting base with 5/16" inlet and a hose clamp. The hose clamp holds the filter to the base when the vent hose is installed.

- 77101** Complete assembly
4634 Replacement Filter ONLY as shown (no chrome) 2" diameter x 1/2" height

Oil Filters

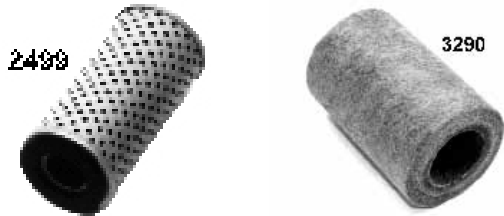

Oil Filters

| PCP | Description |
|------|---|
| 2499 | Cartridge type oil filter for FL 1954-82, XL 1954-80 (63839-53) |
| 3290 | Oil filter for remote oil filter assembly 1948-64 (63840-48A) |



Spin-On Oil Filters

Spin-on oil filters come complete to replace the stock filter unit with no adapting. Available chrome or painted.

| PCP | Finish | Application |
|------|--------|--|
| 2501 | Chrome | 1980-E84 All XL, 1982-86 BT 4-speed, all accessory type filter kits (63782-80) |
| 3839 | Black | Same as above (63810-80) |
| 3841 | Black | 1985-on All XL, 1980-98 all FLT, 1982-94 all FXR (63806-80T) |
| 2500 | Chrome | Same as above (63796-77A) |



Oil Pre-Filters

Pre-filters are constructed of machined alloy with a #40 mesh screen installed to trap large debris and a circular magnetic collar to collect ultra fine ferrous particles, before they reach the engine. The pre-filter unit can be installed in the following locations for 3/8" I.D. oil line:

- Supply line before engine, all models
- Primary scavenger return line on early FLH and FX
- Return line to oil tank on XLCH, FL,EL, UL and models without a factory filter
- External oil return on high pressure heads
- Any high pressure supply or return (use the pre-filter with the 1/8" NPT threaded body)

| PCP | Description |
|-------|-----------------------------|
| 17504 | With 1/8" NPT threaded body |
| 17505 | With 3/8" barbed end |



Oil Filter Adaptors

| PCP | Application |
|-------|--------------------------------|
| 59105 | 1982-on FXR |
| 2500 | Filter for above models listed |
| 25290 | Rubber base seal |

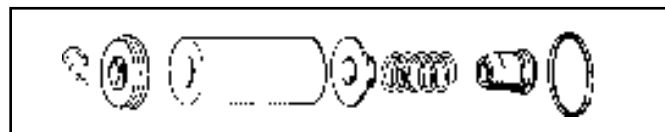

Oil Filter Hardware Kit (No Filter Element)

Includes all small hardware parts pictured for an oil filter rebuild on XLH 1954-78, FX 1971-81, FL 1965-81. USA made. 4690



FXST Style Oil Filter Kit

Frame mount kit features late 1984 styling of the FXST unit. Bolts directly behind shifter plate on all FX-FL-FLT, 1970-on. Can be used as easy access auxiliary unit in addition to filter in tank. Inlet and return lines are stamped on bracket. Bracket is replica of 63802-84 unit, includes chrome filter, oil spigots are copper-brazed. Includes chrome filter and 6' of rubber hose.

| | |
|------|---------------|
| 4847 | Kit with hose |
| 2500 | Chrome filter |
| 3841 | Black filter |

Oil Filters



77233

Hex Nut Spin-On Oil Filters

Available in chrome or black. Hex nut style allows for easy installation and removal. All PCP filters are a low restriction type filter. All K&N filters feature improved pressure relief valve, anti-drain back valve and heavy duty base plate with improved rolled seal.

| PCP | K&N | Finish | Size | Application |
|-------|-------|--------|-------|----------------------|
| 77233 | 77224 | Chrome | Short | 1980-E84 (63782-80T) |



77304

77204



77302

77202

Perf-Form Oil Filters

Top quality, made in USA spin on filters for models from 1980 to present.

The 2-1/2" filter features 24 square inches more pleated paper than comparable filters, and an anti drain back valve not found on most other filters. Fits 1980-E84 Sportster models and BT 4-speed L1982-86

PCP Description (HD-3)

| | |
|-------|----------------------------|
| 77202 | Black, each (63810-80) |
| 77302 | Same as above chrome, each |

The 3-1/2" filter is one inch longer than stock to increase the oil capacity of the system. Fits L1984-on Sportsters and most Harley Davidson Accessory Oil Filter Kits.

PCP Description (HD-2)

| | |
|-------|-----------------------------------|
| 77204 | Black, each (63805-80A, 63806-83) |
| 77304 | Chrome, each |



62347

62349

T/L Spin-On Oil Filters

USA made filters have a cured resin paper filter with a metal end cap. Thermal setting adhesive provides a positive seal that prevents foreign particles from circulating through the oil.

| | |
|-------|--|
| 62347 | Chrome, short. L1982-84 FLH-80 Classic; 1982-86 FXWG, FXSB, FXEF; 1979-E84 XL (63782-80) |
| 62349 | Chrome, long. 1980-98 FLT, FLHT, FLHR; 1982-94 FXR, L1984-on XL (63796-77A) |



Perf-Form Oil Filter

Easy-to-install one piece complete oil filter for Big Twins 1965-81 4 speeds and XLH 1954-78 with in-tank filters. Replaces the stock fibre element with pleated paper element.

PCP Description

| | |
|-------|------------------------|
| 77200 | Each (HD-1) (63840-53) |
| 77201 | Box of 10 (63840-53) |



Felt Oil Filter Element

Original style fits BT 1953-E82 and 1954-78 XLH models.

| | |
|-------|----------|
| 77320 | 63888-53 |
|-------|----------|

Oil Filter Kit



Front Mount Filter

This kit incorporates filter and regulator mount for Big Twins 1975-99. Includes chrome filter, hose fittings, and chrome billet base.

- 77442** Complete kit
- 2501** Chrome filter (imported)
- 77302** Chrome filter (Perf-form)



Oil Cooler-Filter Kit

Includes chrome canister filter FLT type, finned aluminum mounting flange, with hose and clamps. Mounts to most Sportster XLH or FX-FL's.

- 77440** Filter kit
- 2500** Chrome filter



Pura-Flow Oil Filter Kits

Full flow automotive style spin-on oil filter kits. Kits include a chromed heavy-gauge steel bracket, chrome oil filter, and all required hoses and clamps.

- 4685** Fits all 1936-99 Big Twin
- 2500** Chrome filter for above kits



Oil Filter Kit XLH, XLS

Includes chrome filter, hose, clamps and chrome motor mount plates to install on all 1982-84 models except Evo. Installs as engine mount plates and oil filter unit and accepts late peg assembly. Replaces 16210-81 and 16213-81.

- 77445** Complete kit
- 2501** Replacement filter
- 4705** Late style foot rest support



Pura-Flow Oil Filter Kits

Full flow automotive style spin-on oil filter kits. Kits include a chromed heavy-gauge steel bracket, chrome oil filter, and all required hoses and clamps.

Fits XL 1957-77 with 1 motor mount plate, mounts to left front motor mount location.

- 4687** Kit
- 2500** Chr filter for above kit (import)
- 77304** Chrome filter (Perf-form)



BT Chrome Oil Filter Kit 1970-84

Fits 1970-84 nose cone motors when using an outside frame front pipe.

- 59198** Housing and bracket
- 59199** Housing only

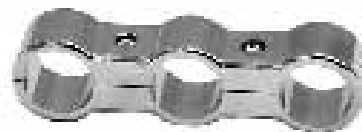

Oil Line Separators

Use these separators to neatly separate and route any 3/8" or 5/16" braided or rubber oil line. Available in polished or chrome alloy.

- 27520** Polished 2 hole (each)
- 27523** Chrome 2 hole (each)
- 27534** Chrome 3 hole (each)

Oil Lines



Russell Chrome Tube Seal Hose Ends

Finish the look of your hose with these easy to install chromed, aircraft quality aluminum ends.

| PCP | Size | ID | Qty |
|-------|------|-------|--------|
| 77697 | #4.5 | 1/4" | 6 pack |
| 77698 | #6 | 5/16" | 6 pack |
| 77699 | #7 | 3/8" | 6 pack |



Stainless Steel Oil Line Kit

Kit includes 10 feet of stainless line and 6 chrome clamps.
77607



Shovelhead Top Oiler

Oils both heads from centre of rocker connector tube, features braided steel upright feed line for early or late lower ends.

77426

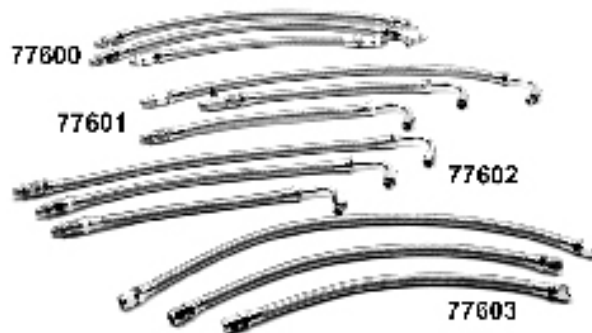

BT Chrome Steel Braided Oil Line Sets

| PCP | Description |
|-------|---|
| 77600 | Shovelhead 1968-80 4 speed models with stock oil tank and inner primary, without elbows |
| 77601 | Shovelhead 1968-80 with wrap around oil tank and stock inner primary, with elbows |
| 77602 | Knuckle, Panhead with wrap around oil tank on rigid frame 1936-64 with elbows |
| 77603 | As above, without elbows |

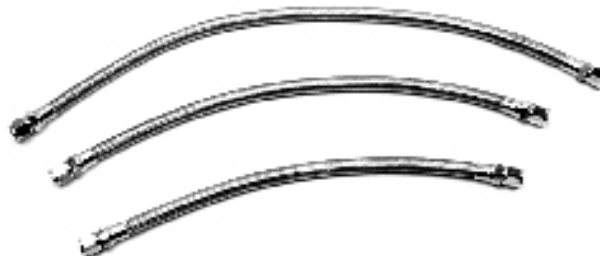

BT Oil Line Without Elbows

Fits most BT engines in all frames with a wrap around oil tank and tin primary covers. Fittings can be unscrewed from lines to make adaptations. Sold each.

| PCP | Size |
|-------|------|
| 77604 | 17" |
| 77605 | 20" |
| 77606 | 25" |

Stainless Braided Gas Line Kit

Includes braided, covered line and econo seal chrome end clamps.

| | |
|-------|-------------------------------|
| 77425 | 2 Ft. of 5/16" w/4 clamps |
| 77420 | 16" piece of 1/4" w/ 2 clamps |



Polished Stainless Steel Hose Lock (Each)

Use this compression fitting to replace conventional hose clamps. Offers a cleaner appearance and superior sealing performance. Sold each.

| PCP | Size |
|-------|------------------------------------|
| 73613 | 1/4" |
| 73614 | 5/16" |
| 73615 | 5/16" For S&S Super E carb fitting |
| 73616 | 3/8" |

Oil Lines



2815



2814

Stainless Steel Braided Oil Lines, Overhead Rocker Arm Oil Lines

- 2815 HD 74" 1966-84 Shovels
2814 Sportster 1957-85



1354

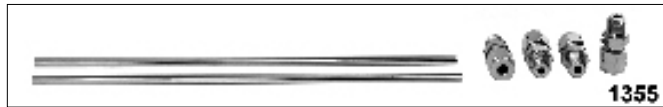

1355

Chrome Oil Line

Perfectly chromed, these replacement rocker box oil lines for Sportsters and Shovelheads include complete fittings and seals.

- 1354 Shovelheads and Stokers (+.200) 1966-84
1355 Sportsters 1957-85 (17324-57A)
4650 Sportster 1957-on magneto only

Shovel Rocker Box Oil Line Fittings

Chrome fittings. Include seals. Fit FX-FL-XL Models.

- 2260 Set of 4
79459 Seals only (25 pk) (63529-57)

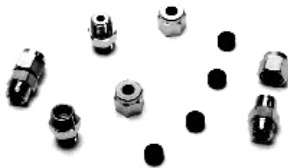

Russell Streetflex Stainless Oil and Fuel Hose

Streetflex hose is engineered to replace stock OEM rubber hoses. Manufactured from superior quality CPE innerlined with a reinforced single wire outer braid for up to 250 P.S.I. Use econo-seal ends or hose clamps to attach to fittings.

- 49850 1/4"x3'
49851 5/16"x3'
49852 3/8"x3'
49853 1/4"x6'
49854 5/16"x6'
49855 3/8"x6'
49856 3/8"x10'
49857 3/8"x25'

Warning: Not for use in brake systems.

XL Breather Pipe

Replaces 24912-52A on XLH-XLCH 1954-76, chrome with fitting nut.

1434



Econo-Seal Hose Ends

Reusable hose clamp fits all gas and oil lines to provide additional support and helps prevent cracking. The 5/16" ends fit 1/4" hose, 3/8" ends fit 5/16" and 3/8" hose.

- 875 1/4"-5/16" chrome (6 pack)
868 5/16"-3/8" chrome (6 pack)



Compression Fitting and Hose Kit

Kit includes 6 compression fittings with 1/8" NPT threads and 10 ft of 3/8" stainless steel braided hose.

77458



3845

Panhead 1963-65 Panhead Oil Line

- | PCP | Application |
|-------|---|
| 3845 | 1963-65 Chrome Y line (62780-63) |
| 21008 | 1963-65 as above, tin plated |
| 10593 | 1963-65 Elbow for above (63542-63) |
| 10572 | 1963-84 Line fittings (63526-57) (5 pack) |

Oil Lines

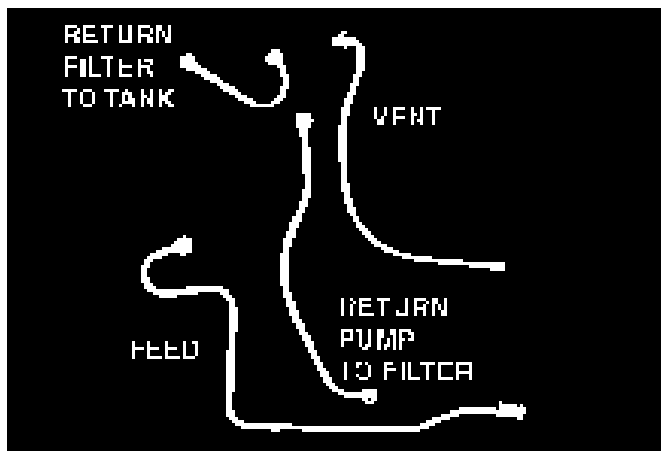

Swing Arm Frame With Filter 1958-64

| Cad | Chrome | Description |
|------|--------|-------------|
| 4658 | 3175 | 4 Piece set |

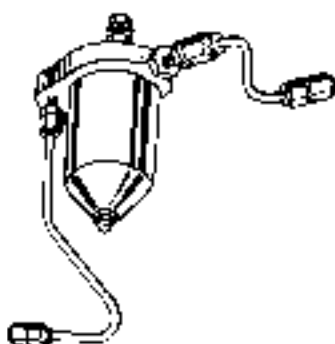

Oil Filter Canister Line Set

2 Piece line set with nuts for rigid or swing arm frames.

| Cad | Chrome | Description |
|-------|--------|---------------------------------|
| 19435 | 4655 | Swing arm line set |
| 19425 | 4656 | Rigid line set |
| 14097 | | Rubber seal (5 pack) (63529-50) |



Oil Canister Rebuild Kit

Includes all small parts and gaskets for rebuilding.
25606



Steel Oil Lines

Fit Big Twin 1936-64 OHV models. Supplied with nipple nuts already attached to fit wrap around and stock oil pumps on models listed. Order oil pump fittings separately.

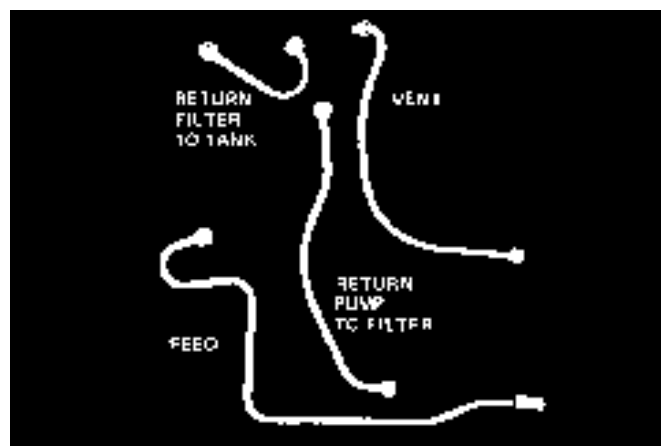

Oil Line Kit for Harley Swingarm Frame

Cadmium-plated oil line kit complete with seals and fittings. This kit fits original HD Swingarm frames with the external oil filter on 1958-64 Big Twins.

| PCP | OEM | Description |
|------|----------|-------------------------------|
| 4658 | | Complete oil line kit (shown) |
| 4659 | 63511-58 | Oil pump feed line |
| 4660 | 63572-58 | Oil tank vent line |
| 4661 | 63506-58 | Oil tank return line |
| 4662 | 63503-58 | Oil Filter return line |

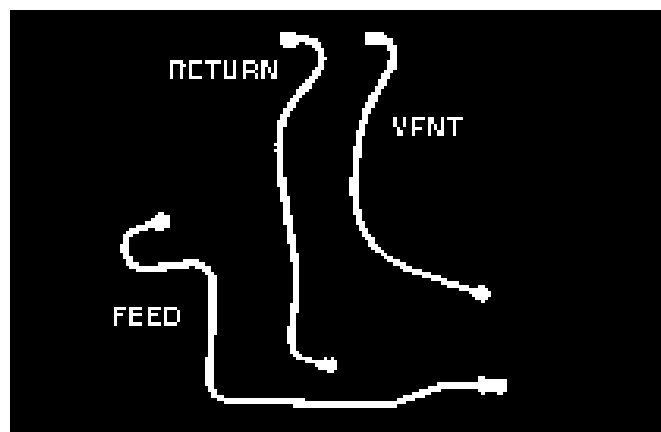

Swing Arm Frame Without Filter 1958-64

| Cad | Chrome | Description |
|-------|--------|------------------------|
| 19432 | 19431 | 3 pc Set |
| 4659 | 3834 | Feed line (63511-58) |
| 4660 | | Vent line (63572-58) |
| 4661 | | Return line (63506-58) |

Oil Line Fitting Kit

These oil line fitting kits include 4 cadmium plated fittings for use on OEM frames when an external oil filter is used. Fittings will work with the aluminium cover oil pump only.

| | |
|------|------------------------|
| 4653 | Rigid frame 1936-57 |
| 4654 | Swingarm frame 1958-64 |

Oil Coolers



Chrome Billet V-Cooler

Cooler measures 4-1/8" wide at top and each tube is 10.5" long and 1-1/8" in diameter. Cooler mounts to front frame tubes.

| PCP | Application |
|-------|------------------------|
| 59209 | Cooler |
| 73530 | 1-1/4" Frame clamp set |
| 73531 | 1-1/8" Frame clamp set |



Dual Cool Chrome Oil Cooler

Features 9" x 1/8" cooling tubes by 3-3/4" long and 1-1/8" wide with reversible top bracket.

59181

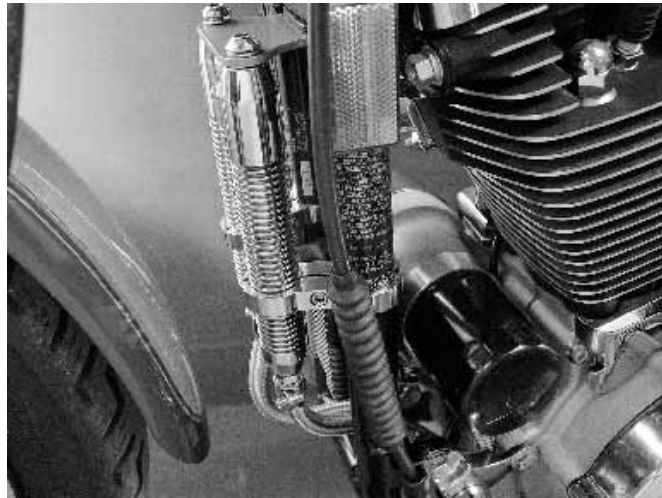

XL Sifton Oil Cooler

Replica style cooler available in black or chrome. Order brackets separately.

| PCP | Finish |
|-------|--------|
| 21637 | Black |
| 21636 | Chrome |

Brackets

| | |
|-------|---------|
| 17278 | 1979-03 |
| 17279 | 1957-78 |

Dual Cool Chrome Oil Cooler

Includes stainless steel hose and adapter fitting for engine to allow use of oil filter. 1971-on models may require bracket modification.

59825 1979-03

Billet Twin Oil Cooler Set

Features 2 independent cooler cannisters with billet clamp set for mounting to 1-1/8" front frame tubes.

59493



Sifton Oil Cooler Kit

Includes Billet dual tube vertical oil filter with Billet mount clamps measuring 10" long and 4-1/8" at top diameter. Includes adapter for filter, SS braided lines and 4 chrome seal ends.

59442 FX 1970-84

Fittings

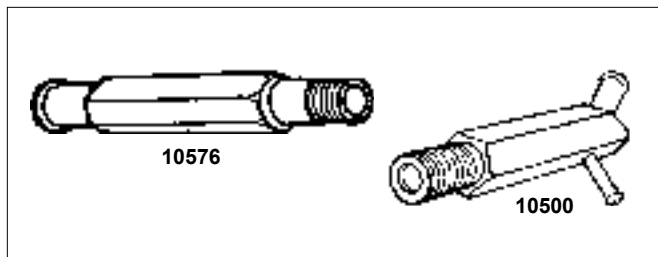

BT Oil Fittings

| PCP | Description |
|-------|---|
| 10576 | Oiler return BT 1965-on (63533-65) |
| 10500 | Oiler T, rear chain BT 1971-78 (63541-70) |
| 16319 | Rear chain oiler clamp (9951) (10 pk) |

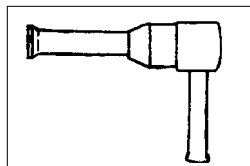

Chain Oiler Fitting

Attaches to inner primary cover on FL, FX 1970-84. Replaces 60549-70. Sold each.
3757 Stock

Bracket Oil House Routing

Replaces OEM 63549-65. Use on all 1965-85 Big Twins.
4244 Zinc

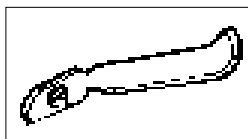

Alloy Generator Oil Filter Adapter

Bolts in place of 2 brush generator on later XL models.

| | |
|--------------|---------|
| 77446 | Adapter |
| 2500 | Filter |



Oil Line Filter Kit

Includes filter and compression fittings for 3/8" SS hose.
73590

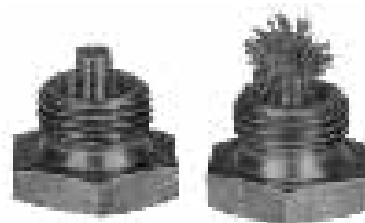

Magnetic Drain Plugs

| PCP | Size | Use |
|-------|----------|-----------------------------------|
| 10610 | 3/8 x 24 | BT Case plug (700) (not magnetic) |
| 10611 | 1/2 x 13 | 74 & XL Trans (707) |
| 10615 | 1/4 x 18 | NPT chain cover (718) |
| 10612 | 5/8 x 18 | Oil Tank & time hole (720) |
| 10616 | 5/8 x 18 | FXR drain (722) |
| 10614 | 1/8 x 27 | As above with hex |
| 10618 | 1/2 x 20 | 74 & 80 Inner primary (60348-65A) |

Prevents metal particles from circulating through engine and transmission cases, oil tanks, etc.

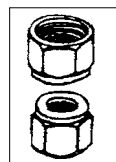

Cad Oil Line Nuts and Seals

| PCP | Description |
|-------|-------------------------------------|
| 10573 | Nuts 1950-64 (pr) (63527-50) |
| 14097 | Rubber seals FL 1949-64 (63529-50T) |

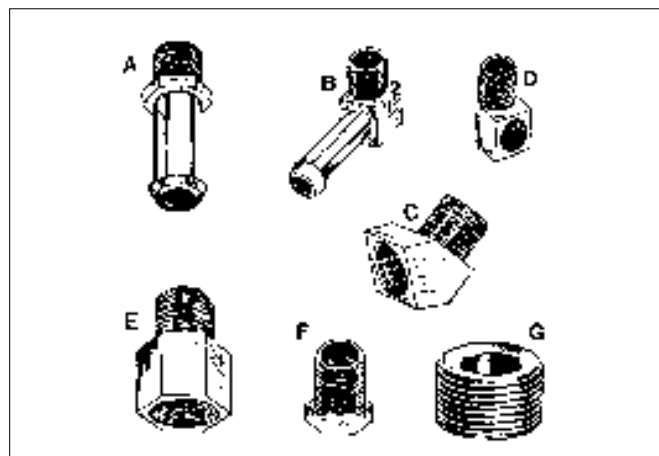

Chrome Male Fittings

Measured in NPT thread and ID of gas/oil line. 5 packs.

| (A) Straight | (B) 90 Degree | Size |
|--------------|---------------|-----------------|
| 10504 | 10502 | 1/8 x 5/16 Hose |
| 10505 | 10517 | 1/8 x 1/4 Hose |
| 10575 | 10518 | 1/8 x 3/8 Hose |
| 10506 | 10519 | 1/4 x 5/16 Hose |

Chrome Male-Female Fittings

| PCP | Type | Size |
|-------|----------------------------|---------------|
| 10507 | (C) 45 degree street elbow | 1/8 x 1/8 NPT |
| 10520 | (D) 90 degree | 1/8 x 1/8 NPT |
| 10508 | (E) straight | 1/8 x 1/8 NPT |

Male Plugs (5 pack)

| PCP | Size |
|-------|--|
| 4698 | (F) 1/8 NPT, chrome brake tee 1958-72 (42311-58) |
| 10514 | (F) 1/4 NPT, plain |
| 10525 | (G) 3/8 NPT hex socket plug, plain |

Oil Line/Accessories



Reinforced Black Fuel/Oil Line

Neoprene fuel and oil line for all Harley models. Available in shop supply 25-foot rolls, this top quality line is reinforced with high strength rayon. Neoprene outer cover resists oil and grease for years of trouble-free service.

- 3055** 1/4" x 25 feet
- 3056** 5/16" x 25 feet
- 3057** 3/8" x 25 feet



Stainless Steel Braided Hose

- To fit 3/8" lines.
- 6250** 6 foot piece
 - 77430** 10 foot roll
 - 77431** 25 foot roll



Nylon Fuel Line

- Sold in 25-foot rolls.
- 3048** 1/4" x 25 feet
 - 3052** 5/16" x 25 feet
 - 3054** 3/8" x 25 feet



Mini Hose Clamp

This quality clamp fits all 3/8" to 5/8" outside diameter hose.

- 3846** 3/8-5/8 Gas (10 pk)
- 3850** 1/2-3/4 Oil (10 pk)

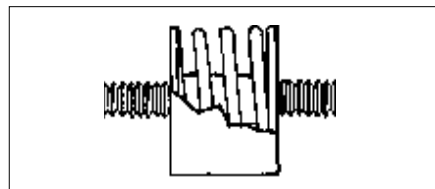

- | PCP | Description |
|--------------|--|
| 23006 | Heavy-duty mount (62563-65) (10 pk) |
| 1154 | Regular mount (62563-65) (10) |
| 23069 | 5/16" x 1/4" XL oil tank mounts (62569-94) |



Plain Finish Alloy Hose Clamp

Fits all 5/16" and 3/8" rubber oil-gas hose.

- 2968** 5/8" I.D. (each)



Econo-Seal Hose Ends

Reusable hose clamp fits all gas and oil lines to provide additional support and helps prevent cracking. The 5/16" ends fit 1/4" hose, 3/8" ends fit 5/16" and 3/8" hose.

- 875** 1/4-5/16" chrome (6 pack)
- 868** 5/16"-3/8" chrome (6 pack)



Stainless Steel Braided Hose

- To fit 1/4" lines.
- 77432** 10 foot roll
- To fit 5/16" lines.
- 77433** 5 foot roll
 - 77434** 10 foot roll
 - 77435** 25 foot roll



Oil Line Separators

Machined from aluminum, these oil line separators neatly separate and route any 3/8" or 5/16" stainless steel or rubber oil lines. Sold each.

- 27520** Polished
- 27521** Blue
- 27522** Black
- 27523** Chrome
- 27524** Red
- 27534** Chrome 3 hole



Billet Oil Star Line Holder (each)

Polished billet with chrome tie wraps. Takes up to 3 oil lines and keeps them in one bundle. For 3/8" oil lines and sold each.

- 71005**



Oil Line To Frame Clamps

Allows 5/8" O.D. oil lines to be clamped to frame tubes. Chrome, sold each.

- | PCP | Size |
|--------------|--------|
| 27527 | 1" |
| 27528 | 1-1/8" |
| 27529 | 1-1/4" |